

### Customer Service Information

**Seville Classics, Inc.**

Telephone: (800) 323-5565

Fax: (310) 533-3899

Hours: 8:30 AM – 4:30 PM (PST)

Email: [Support@SevilleClassics.com](mailto:Support@SevilleClassics.com)

Online Store: [www.SevilleClassics.com](http://www.SevilleClassics.com)

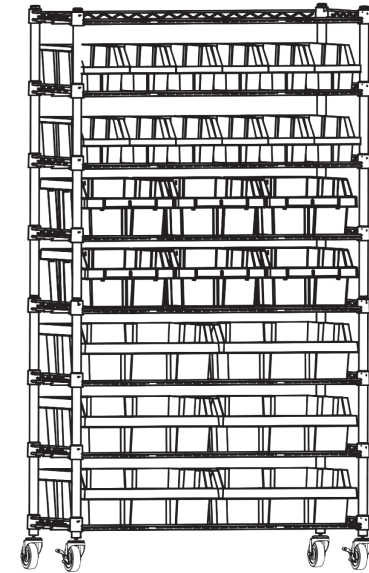

## 8-Tier 24-Bin Commercial-Grade NSF-Certified Bin Rack

Patented Design. US Pat. #7,325,697

### Dimensions:

36" W x 14.25" D x 63.5" H



**Model #: SHE16508BB / SHE16528B / SHE16525B**

### Assembly Instructions

You can view an assembly video by scanning the QR code

## Thank you for choosing Seville Classics!

We hope that you enjoy your new storage bin rack.  
Please read through this user guide for parts list, assembly instructions.



We recommend using two people to assemble the unit.



### Parts List



A. Shelf (8 pcs)

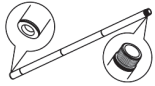

B. Bottom Poles (4 pcs)

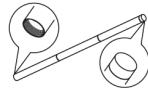

C. Top Poles (4 pcs)

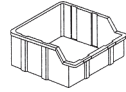

D. Extra-Large Bins (6 pcs)

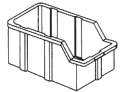

E. Large Bins (6 pcs)

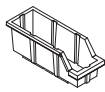

F. Medium Bins (12 pcs)



G. Dividers (10 pcs)



H. Slip-Sleeves (33 pairs)



I. 3" Locking Wheels (2 pcs)



J. 3" Wheels (2 pcs)



K. Labels (36 pcs)

### Tip-over Prevention Hardware Kit

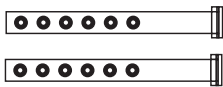

L. Straps (2 pcs)

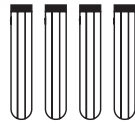

M. Anchors (4 pcs)

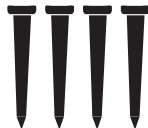

N. Screws (4 pcs)

Feel free to contact our customer service team if you need help with assembly, have questions, or need any missing parts. Customer service is available to assist you in English and Spanish.

Please make sure you have all the parts on this list.

If you are missing parts, contact us for replacements at (800) 323-5565 or send an email to Support@SevilleClassics.com.



## WARNING

- **WARNING! DO NOT** move the shelving system when loaded. Always check that the wheels are tightly screwed into the poles before moving. The wheels can only support a maximum of 500 lbs. Immediately replace wheels that are worn or damaged.
- **CAUTION! DO NOT** move the bin rack system with the bins extended out of the rack.
- **CAUTION!** Use the tip-over prevention hardware kit to ensure the bin rack does not tip over.
- **CAUTION! DO NOT** stand on or climb on the rack.
- **CAUTION! DO NOT** drop heavy items on the shelves.
- Place heavier items on the lower shelves and lighter ones on the top shelves.

Please visit [sevilleclassics.com](http://sevilleclassics.com) to shop our wide range of products.

### Tip-Over Prevention Instructions

Per the assembly instructions below, a tip-over prevention hardware kit is recommended. Secure wall straps to wood studs whenever possible. Avoid water or electric lines when securing the shelf to the wall.

Loop the **STRAPS (L)** around the rear poles of the rack or the back of the upper shelves.

Mark the installation points through the holes in the strap with a pencil.

**For Dry Wall:** Drill pilot holes into points and insert **ANCHORS (M)**. Attach with **SCREWS (N)**.

**For Wood Studs:** Use **SCREWS (N)** to attach **STRAPS (L)** to studs.

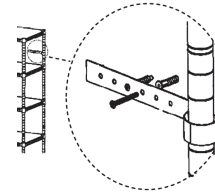

Horizontal

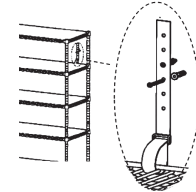

Vertical

### Note:

Please be considerate of the environment and recycle the brown box the item was delivered in along with all applicable packaging materials. Thank you.

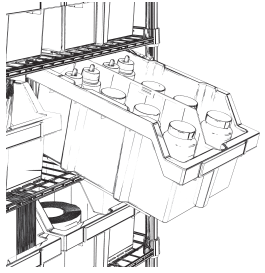

The tiltable bins provide easy access to stored items. A simple extension and tilt of the bins brings items forward for easy access.

Weight capacity	Per shelf	Overall
On wheels	62.5 lb (28.4 kg)	500 lb (226.8 kg)

Shop for additional bin rack parts and accessories at [sevilleclassics.com](http://sevilleclassics.com).

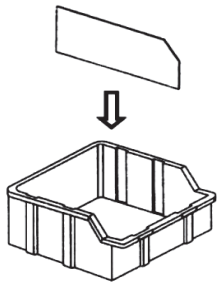

**Bin dividers (6-Pack)**, Model #: WEBK408 (yellow) or WEBK401 (gray)  
**Medium bins (3-Pack)**, Model #: WEBK407 (yellow) or WEBK403 (gray)  
**Large bins (3-Pack)**, Model #: WEBK406 (yellow) or WEBK400 (gray)  
**Extra-large bins (2-Pack)**, Model #: WEBK405 (yellow) or WEBK402 (gray)

## STEP 1.

Screw-in either **WHEELS (I & J)** into the **BOTTOM POLES (B)**.

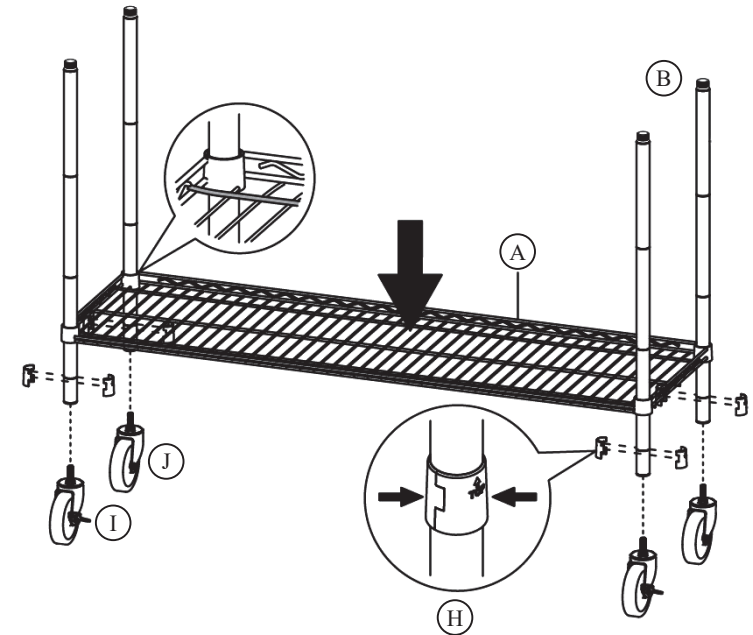

## STEP 2.

Snap **SLIP SLEEVES (H)** around the grooves on the **BOTTOM POLES (B)** for the lowest shelf. Fit **SHELF (A)** over slip shelves. Push the shelf down until snug.

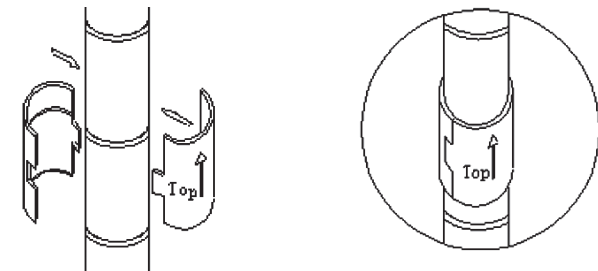

### STEP 3.

Repeat **STEP 2** for the next 2 shelves.

Screw-in the **TOP POLES (C)** onto the **BOTTOM POLES (B)**.

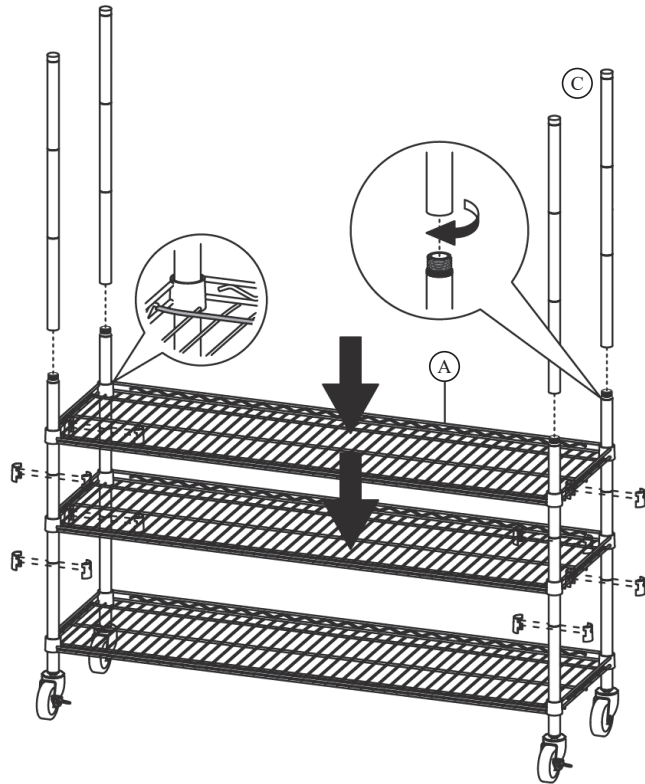

### STEP 4.

Snap the **SLIP SLEEVES (H)** around the grooves on the top poles for the remaining 4 shelves.

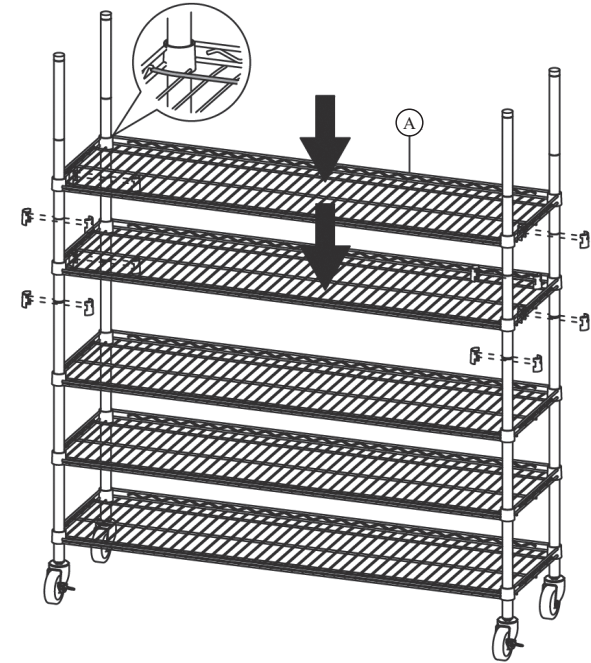

### STEP 5.

Insert the **LABELS (K)** into the front of the **EXTRA-LARGE BINS (D)**, the front of the **LARGE BINS (E)** and the front of the **MEDIUM BINS (F)**.

Insert the **DIVIDERS (G)** into the bins as needed.

Place the bins onto the shelves. Your bin rack system is now assembled and ready to use.

