

ETI Solenoid Full Cool-Down Thermal Stress Analysis: 254-A1000-INFO_07-02-2014 Design

Bill Schneider/ Tom Willard

12 June 2014

Cool Down Analysis

- JLab performed detail FEA analysis for the Solenoid Cool Down
 - These included a transient analysis based on a linear drop in the supply temperature
 - Variable flow rate to get potential temperature profile
 - The profile was then put into the detail structural model to calculate stresses developed
 - This work was completed and reviewed in June/July 2014

Method

- Body temperatures from previous cool-down transient thermal analysis imported into static structural model
 - Gravity load applied at first load step
 - Mechanical material properties imported from previous structural analysis
 - Coil smeared orthotropic Young's Modulus, Poisson's Ratio, and CTE imported as a function of temperature
 - Worst-case found by comparing stresses at 3 cool-down transient thermal analysis operating point temperature profiles: $T_{OP}=220$ K; $T_{OP}=180$ K; and $T_{OP}=140$ K

Estimated and Design Heat Loads

Heat Load	Type Load	ETI Power (W- g/s)	JLAB Power (W-g/s)	Design Capacity (W-g/s)	Max Temp (K) ETI/JL/Design Capacity
Magnet 4K	Liquefaction*	2 – 0.1	4 – 0.2	20 -1	5.1/5.1/5.1
Magnet Shield	Liquefaction*	34 - 0.1	50 - 0.2	300 -1	80/53/63
SST 4K	Refrigeration	N/A	~10	~20	-/5.5/5
SST Shield	-	N/A	N/A	N/A	N/A
Primary U-tubes	Refrigeration	N/A	~10	N/A	N/A

Maximum Helium Cool-Down Flowrate vs Supply Temperature

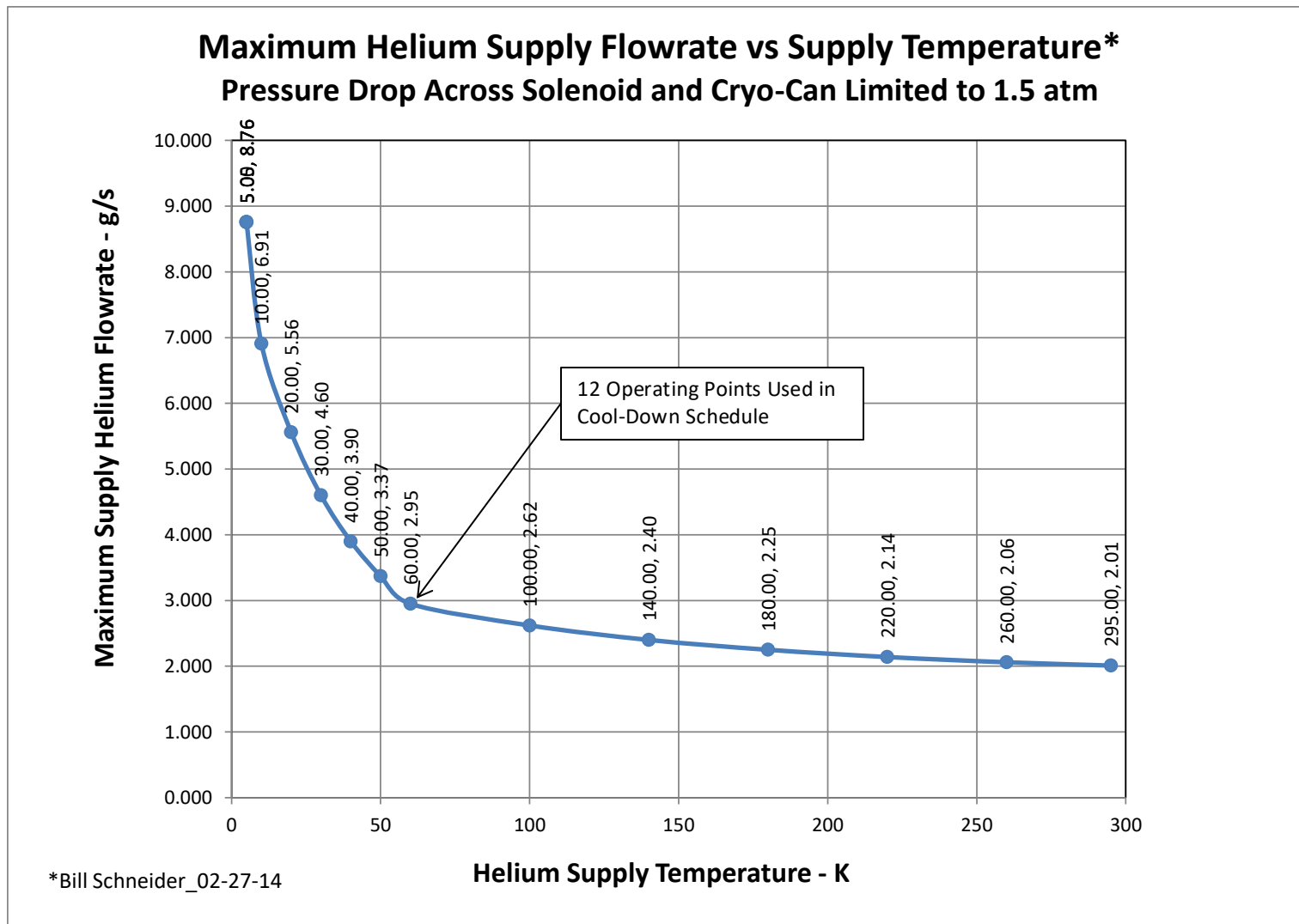

Cool-Down Temperatures vs Time (AS Analyzed)

Cooling Schedule: 29.4 days to 5 K Helium; Cu Bridge Thickness = 4.8 mm

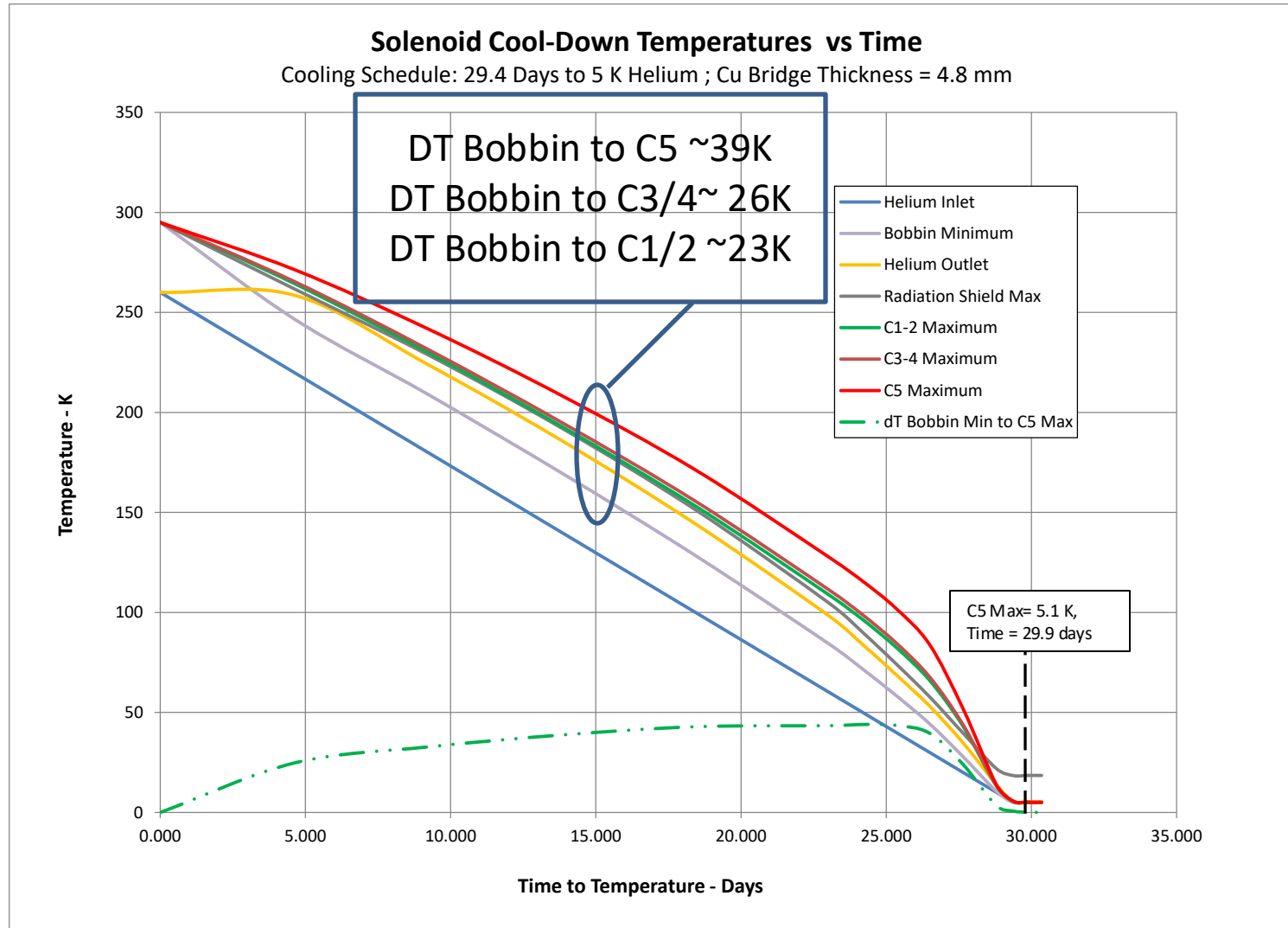

Cool-Down Temperatures vs Time (As in Procedure)

Cooling Schedule: 29.4 days to 5 K Helium; Cu Bridge Thickness = 4.8 mm

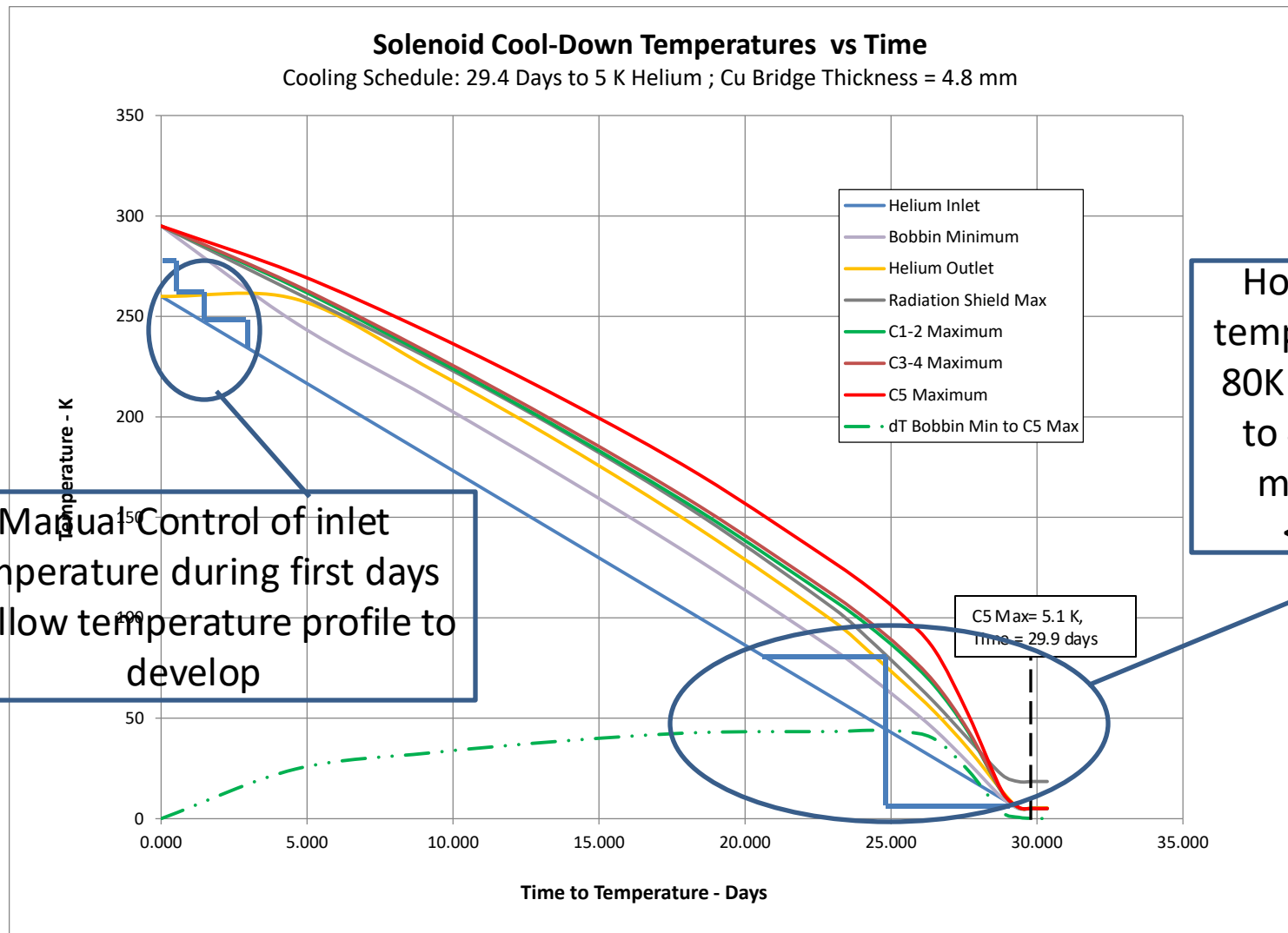

Cold Mass Quarter Symmetry: Solid Model

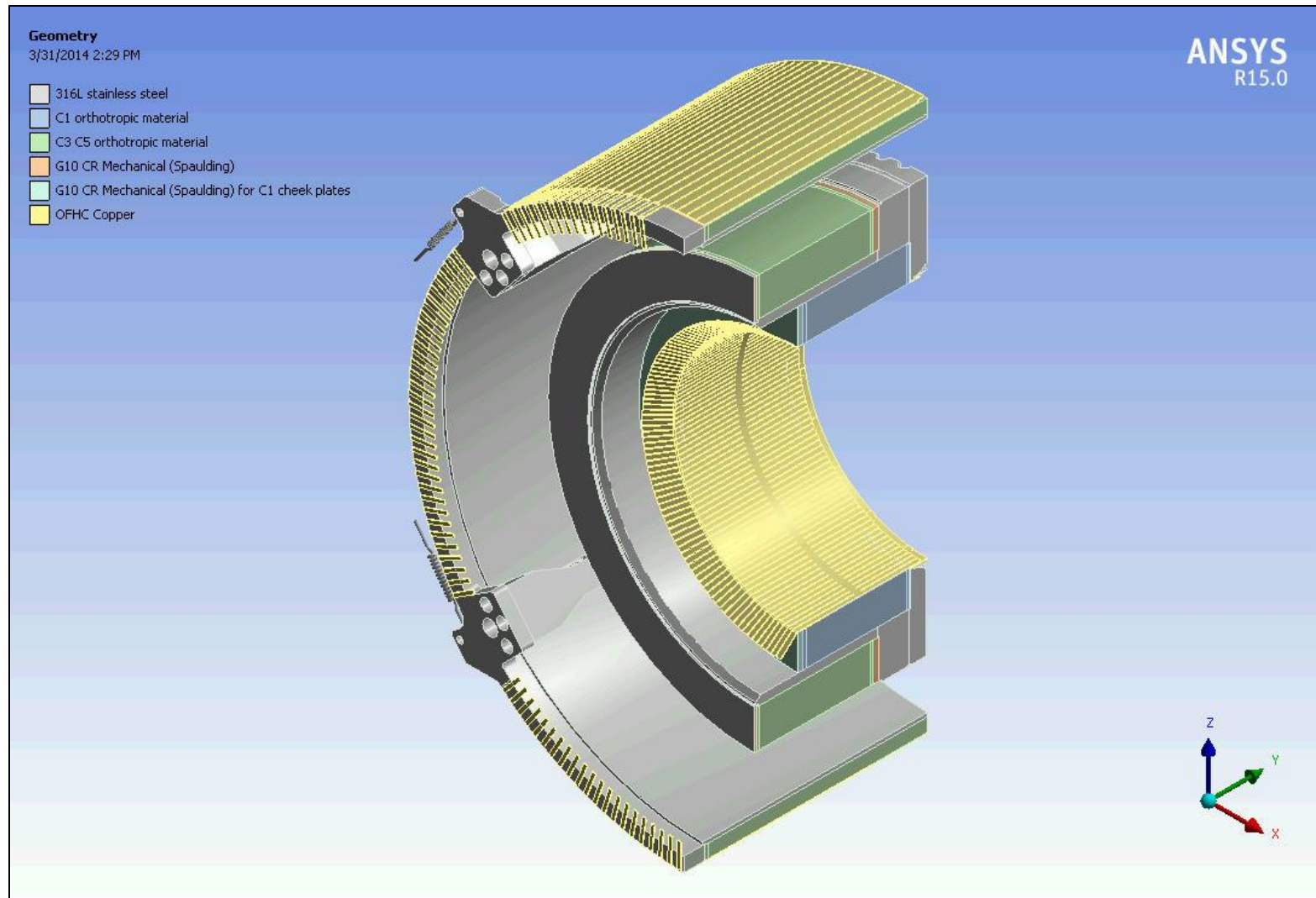

Boundary Conditions: Two Symmetry Planes and Gravity

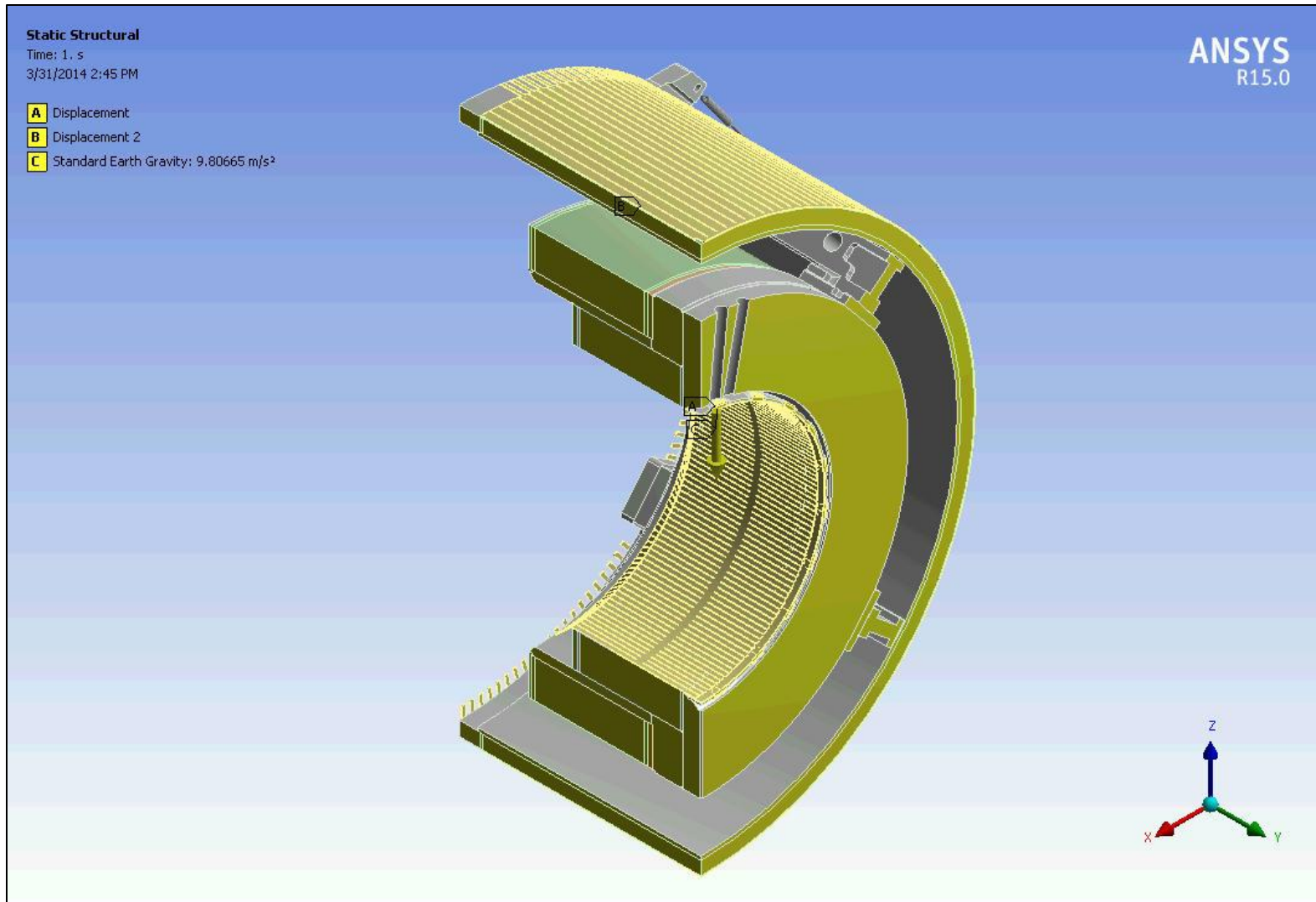

Combined Radiation Shield and Cold Mass Cool-Down: Temperature

Time = 4.6 days

C: Copy of Cold Mass+Radiation Shield_Cool-down Schedule Option 4_4.8 mm Cu Bridges

Full Model Temperature_First Step

Type: Temperature

Unit: K

Time: 398128

4/8/2014 7:14 AM

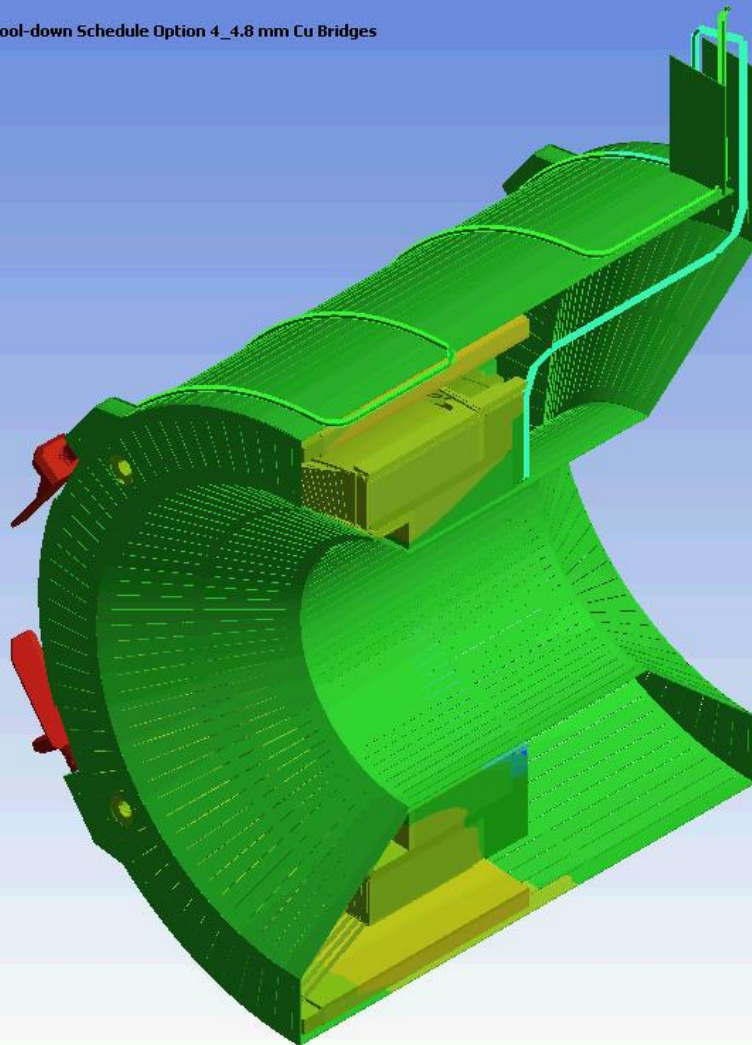
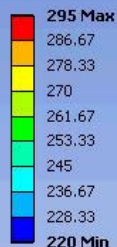

ANSYS
R15.0

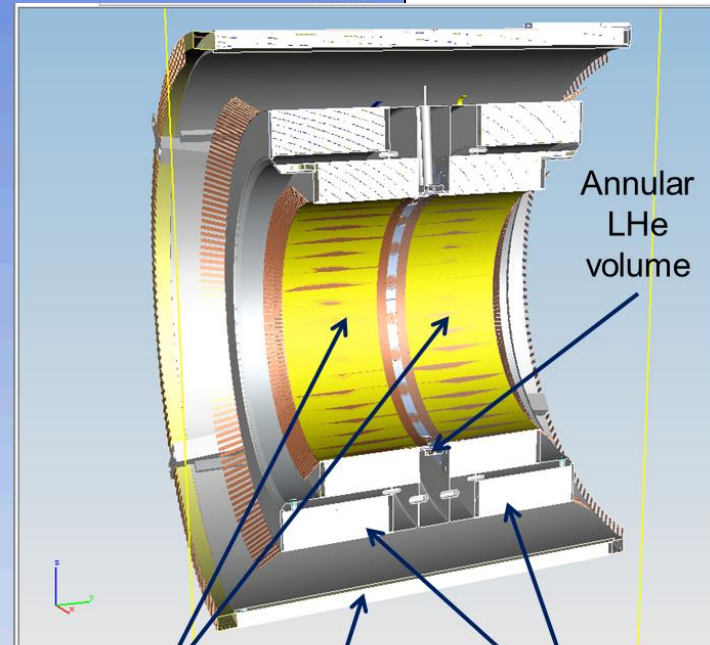

Two Inner Coils

Shield Coil

Two Intermediate Coils

Boundary Condition: Imported Body Temperature

Cool-Down Transient Analysis Results: Operating Point Temperature = 220 K; Time = 4.6 Days

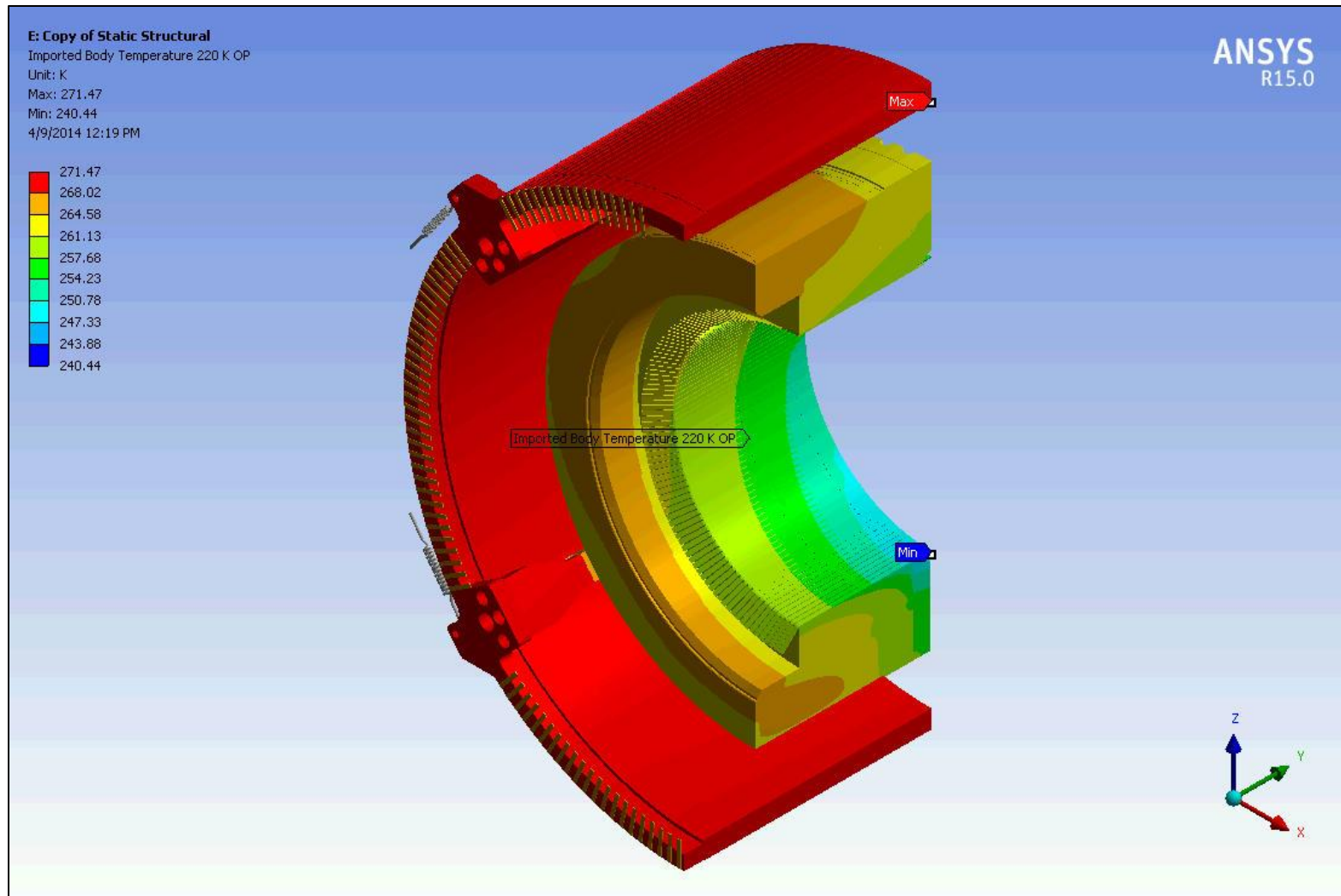

Worst-Case Results: Coil Hoop Stress

Cool-Down Transient Analysis Results: Operating Point Temperature = 220 K; Time = 4.6 Days

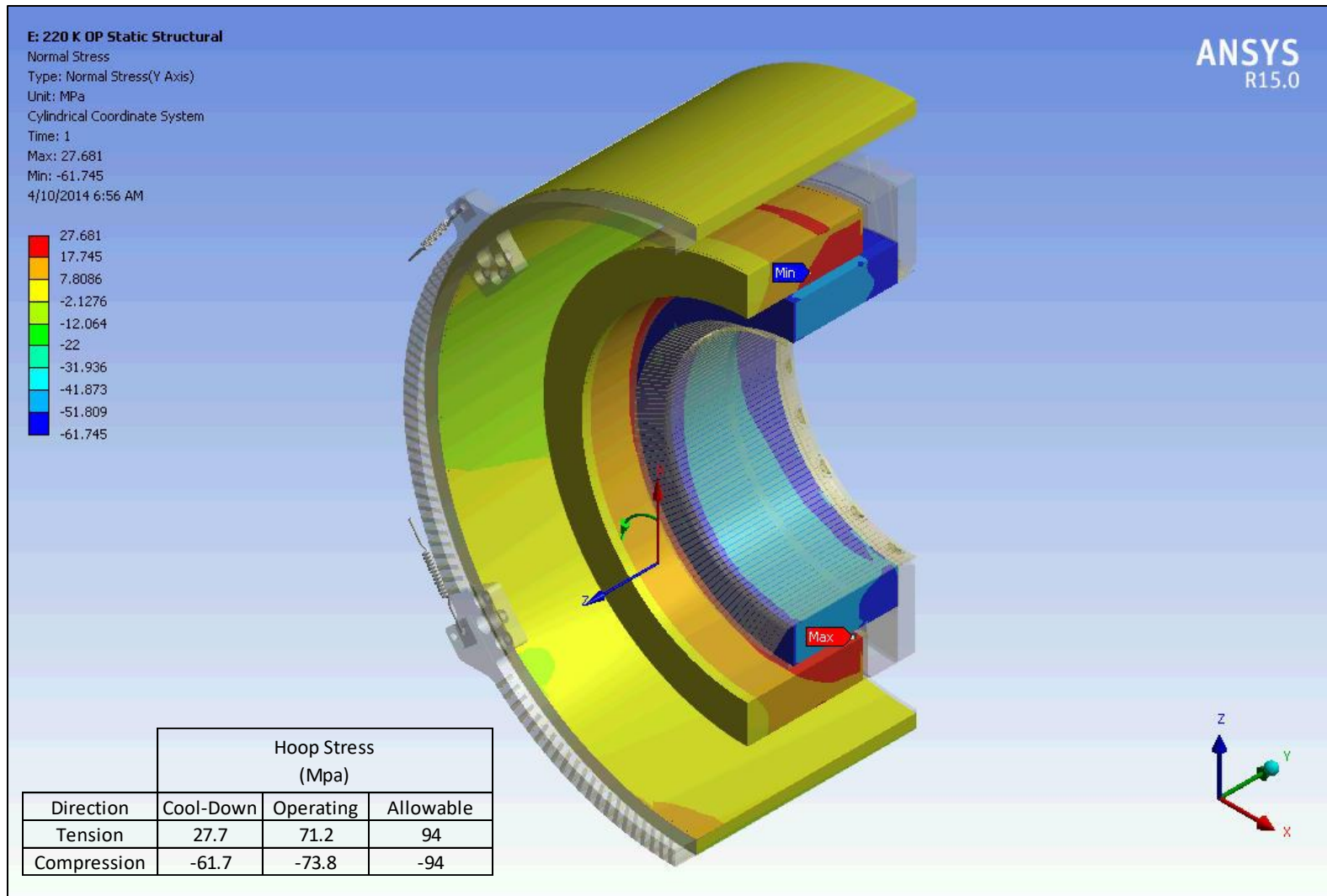

Worst-Case Results: Bobbin Equivalent Stress

Cool-Down Transient Analysis Results: Operating Point Temperature = 140 K; Time = 13.8 Days

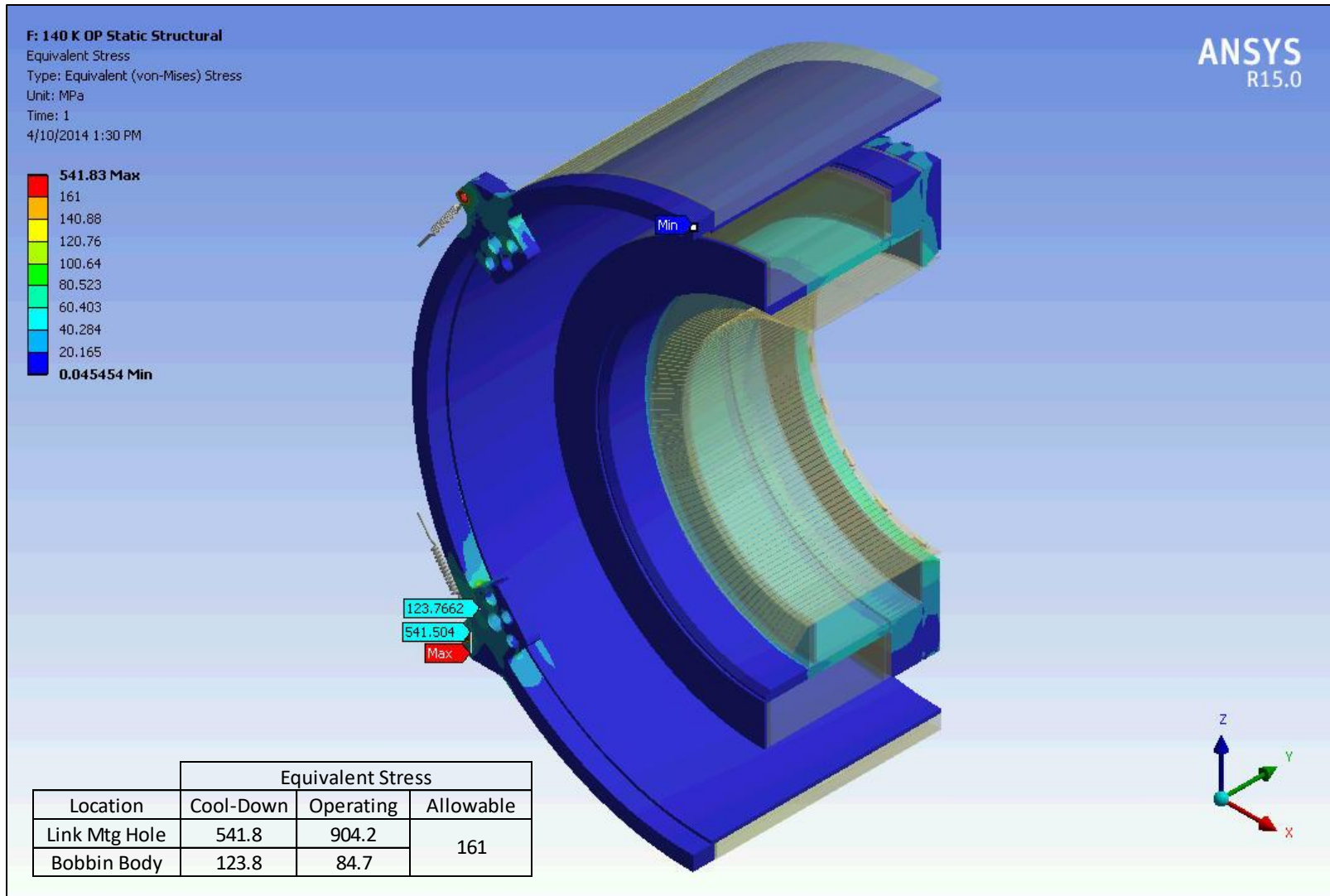

Maximum Coil Hoop Stress

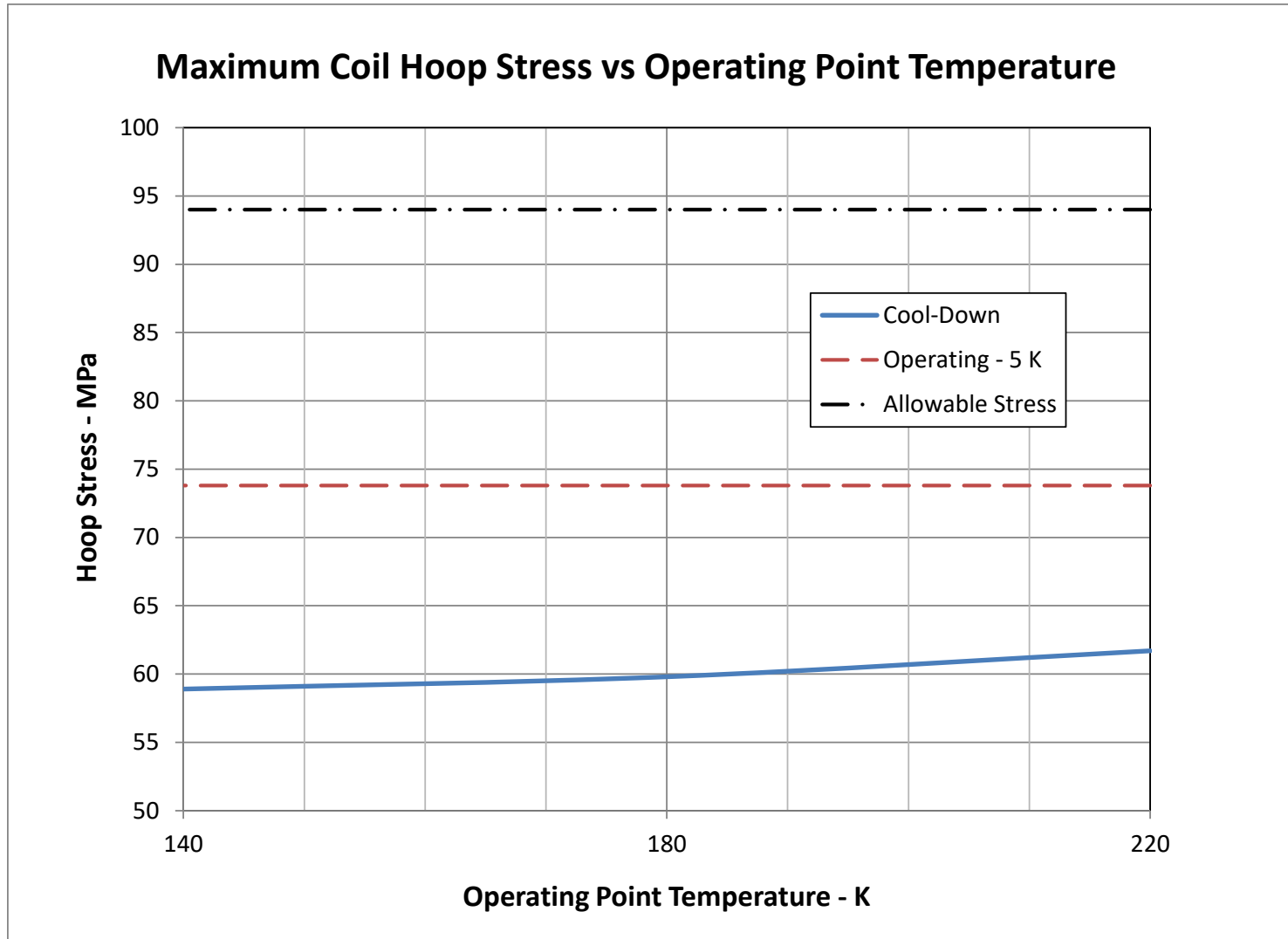

Conclusions

- Worst-case cool-down coil thermal stress occurs at the 220 K operating point
 - The maximum coil stress is in C1, equal to 61.7 MPa, which is below both the maximum operating stress (73.8 MPa) and the maximum allowable (94 MPa)
- Worst-case cool-down bobbin thermal stress occurs at the 140 K operating point
 - The maximum bobbin stress is 123.8 MPa, and is below the maximum allowable (161 MPa)