



National Spherical Torus eXperiment Upgrade

NSTX-R

Update: Inner TF Bundle Insulation Stress Analysis

Tom Willard

July 27, 2019

References

1. ANSYS Archive File: NSTX-R TF Bundle Insulation Stress Analysis_Full Cyclic Sym_07-22-19.wpbz
2. ANSYS Archive File: NSTX-R TF Bundle External Load Path_07-23-19.wpbz
3. ANSYS Archive File: NSTX-R TF Bundle Insulation Delamination Study_07-23-19.wpbz
4. Flex Strap Calculation
5. Torque Transfer Device Calculation

Upper Umbrella Region

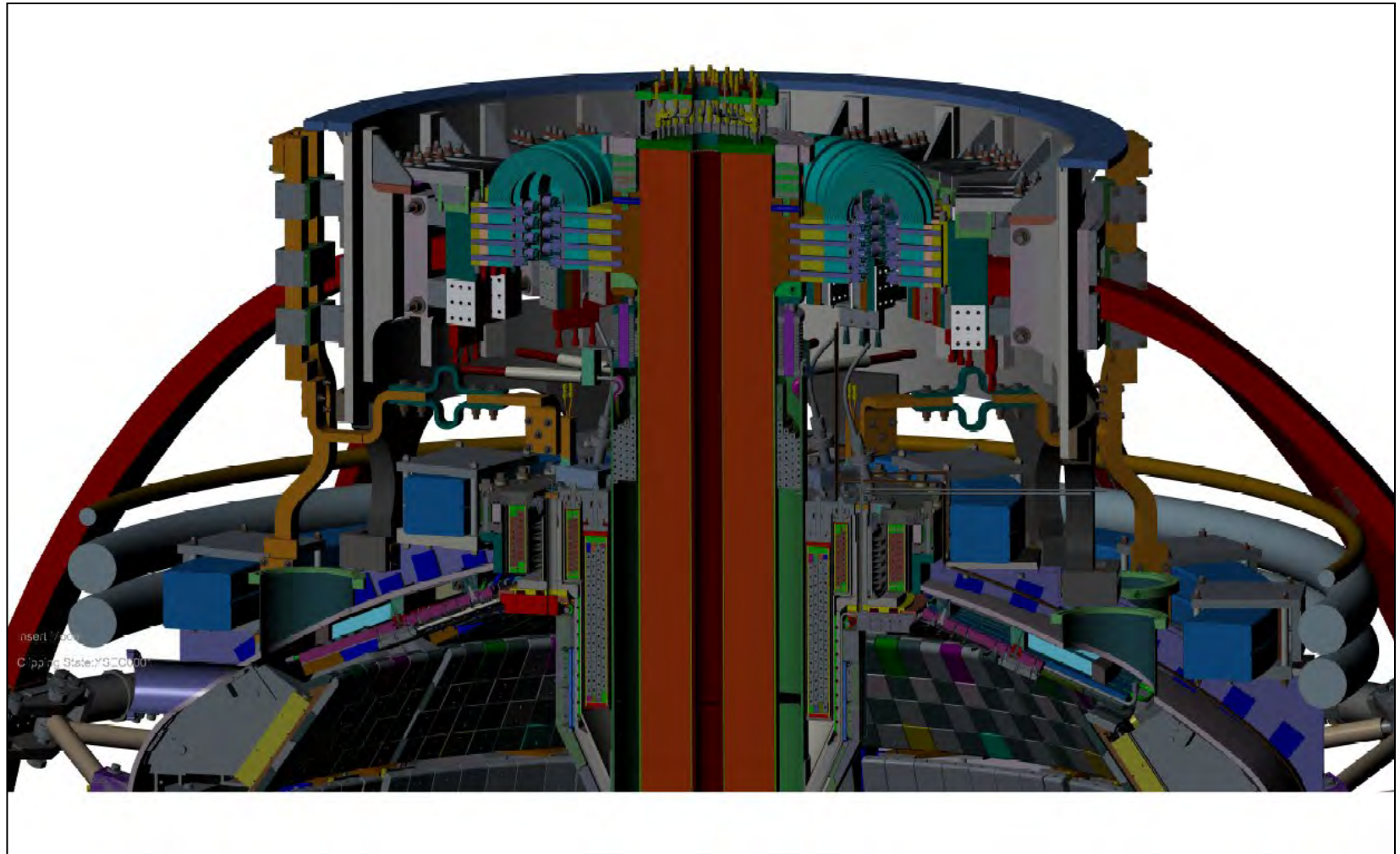

Upper Umbrella Region: Flex Strap and Flag Detail

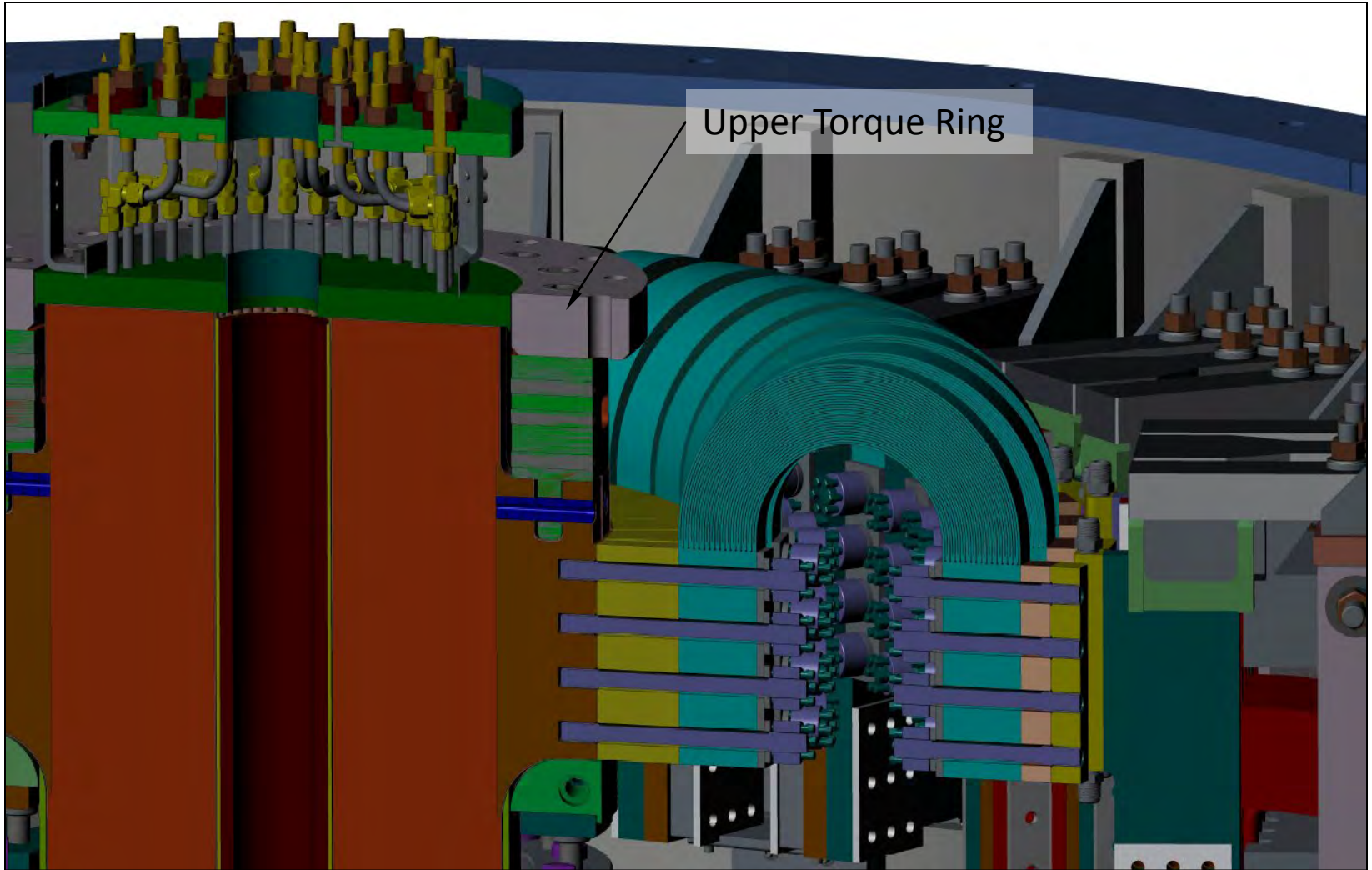

Lower Umbrella Region

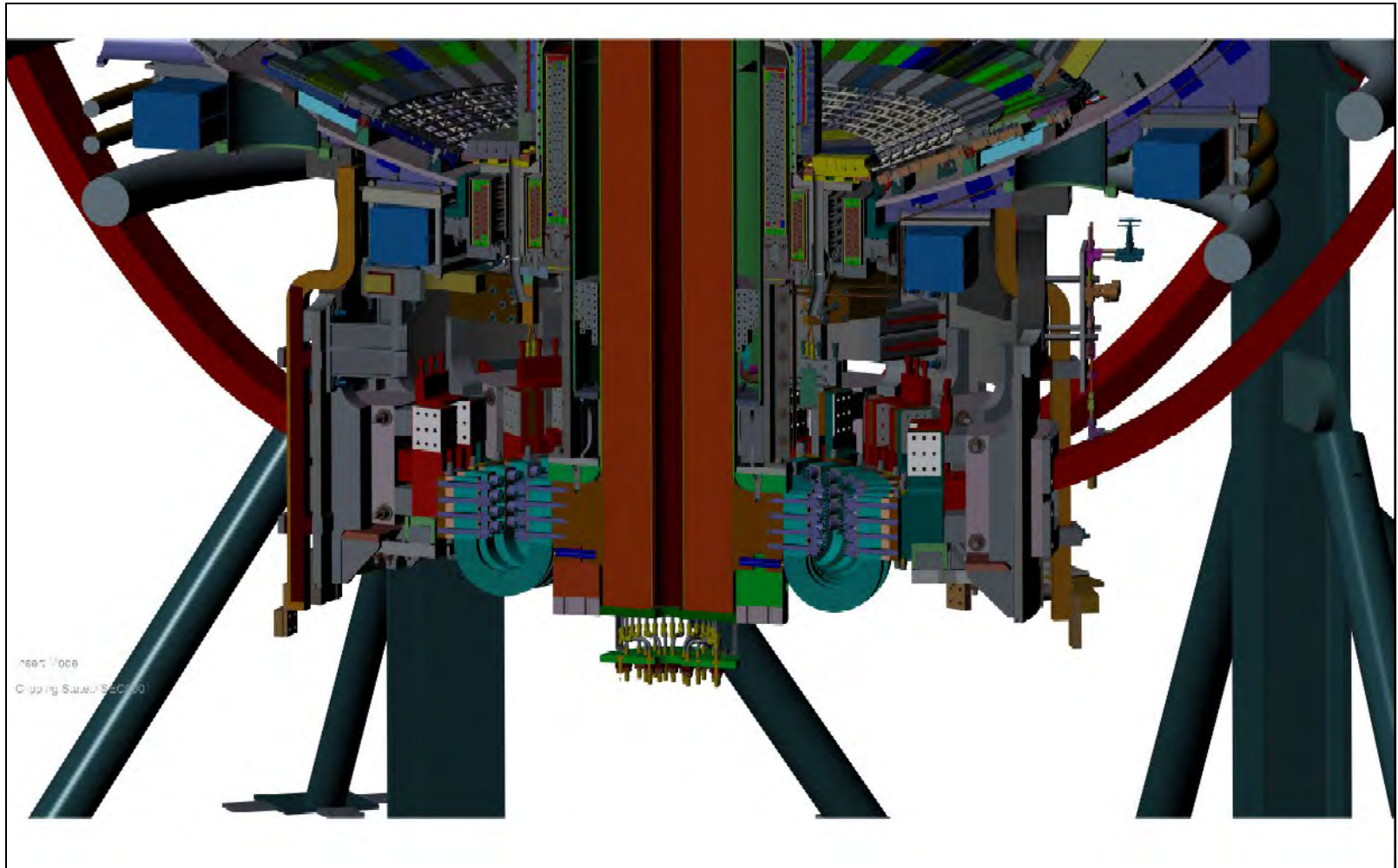

Lower Umbrella Region: Flex Strap and Flag Detail

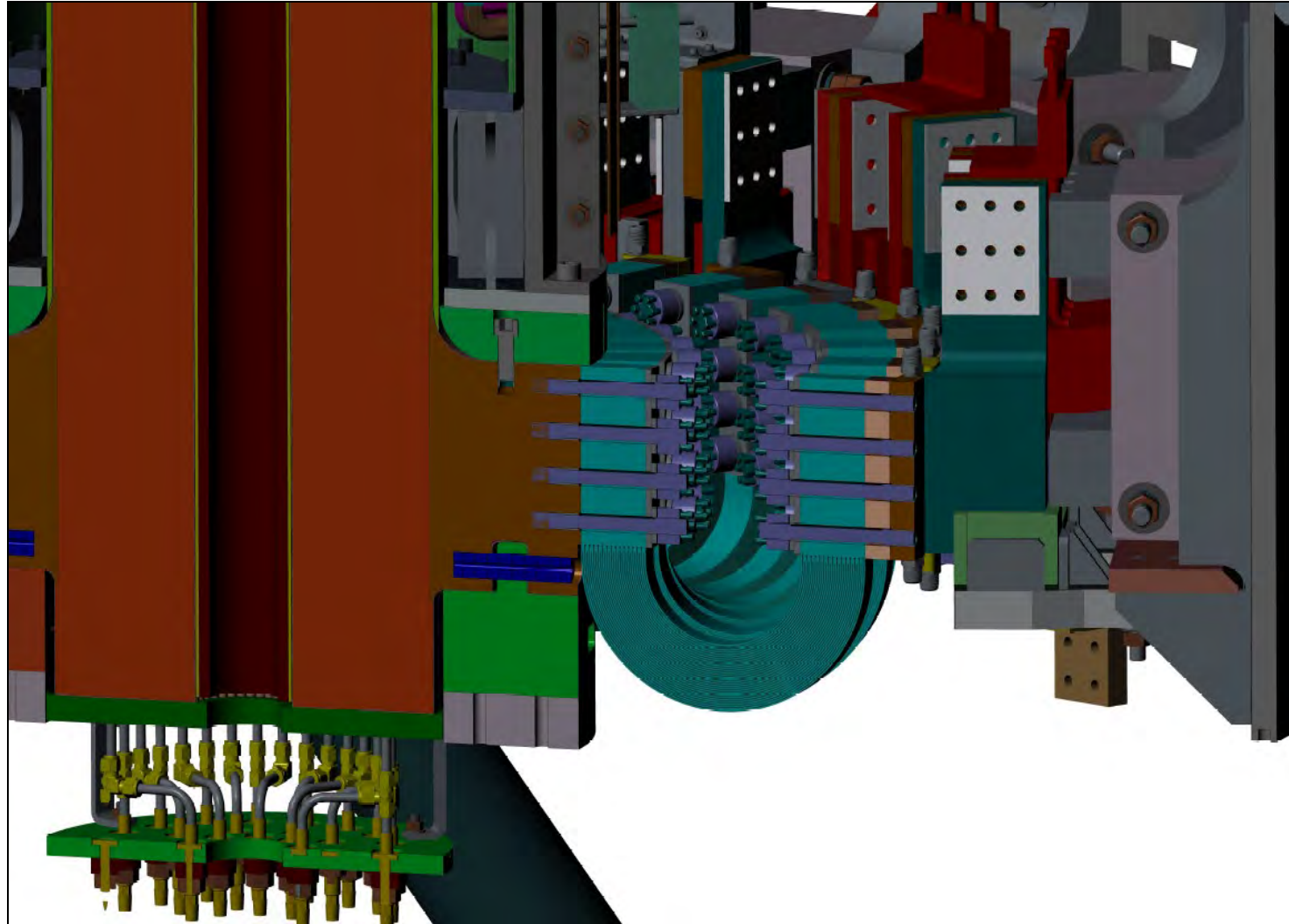

Upper Umbrella Region: Cross Section

OH Coil and Preload Assy Detail; Centerstack Case Not Shown

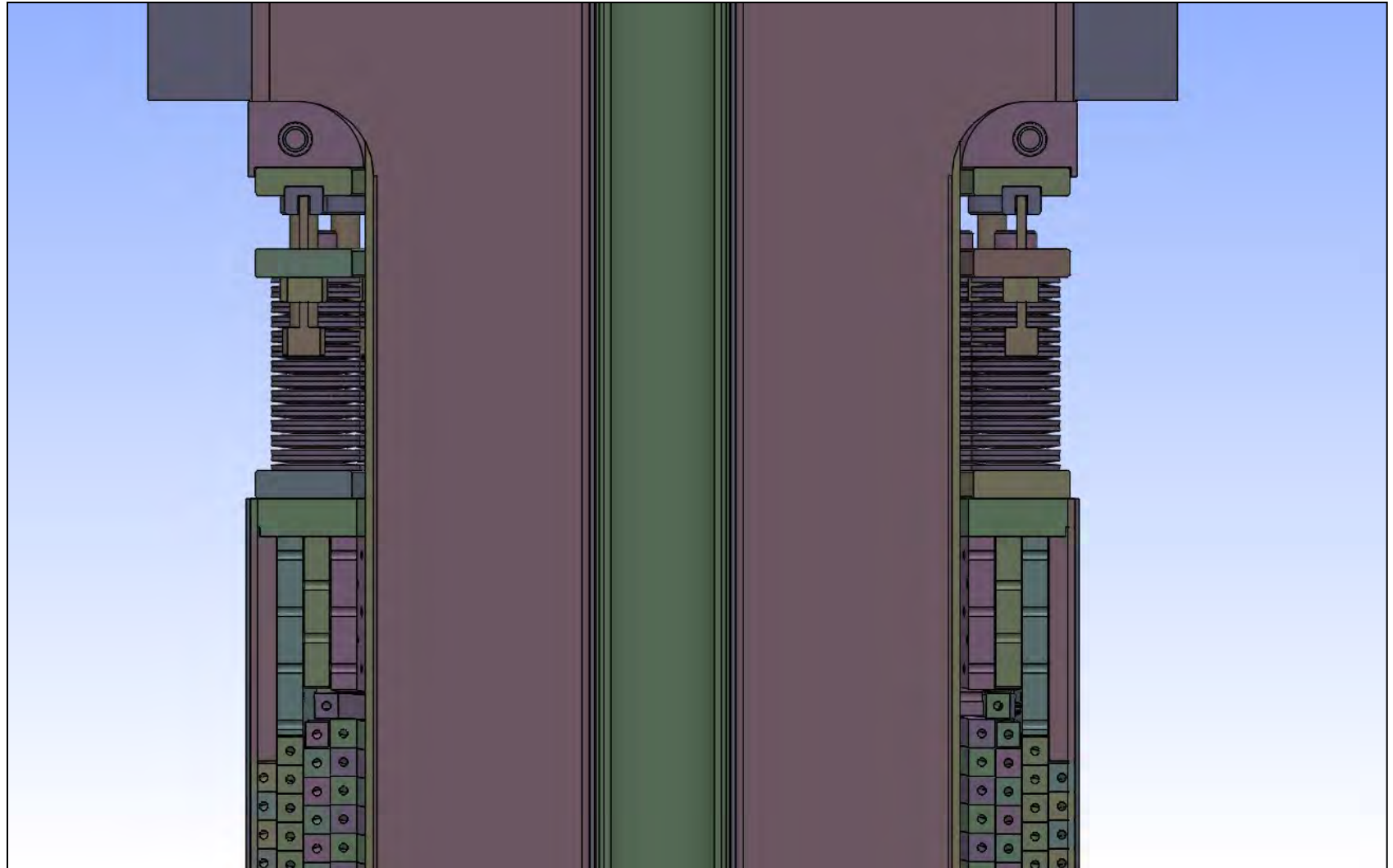

Lower Umbrella Region: Cross Section

OH Coil and Skirt Assy Detail; Centerstack Case Not Shown

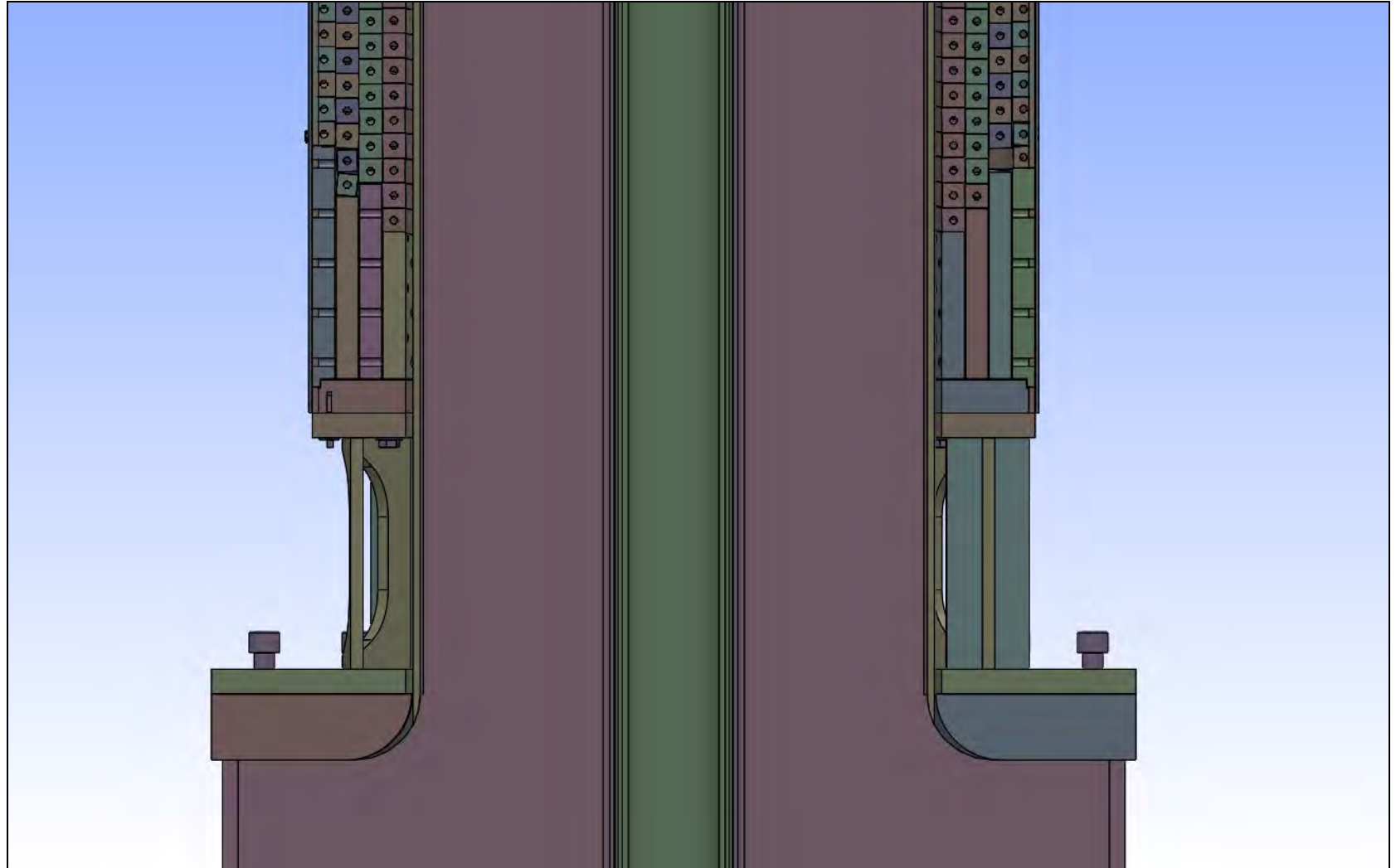

WorkBench Project Page: Simplified

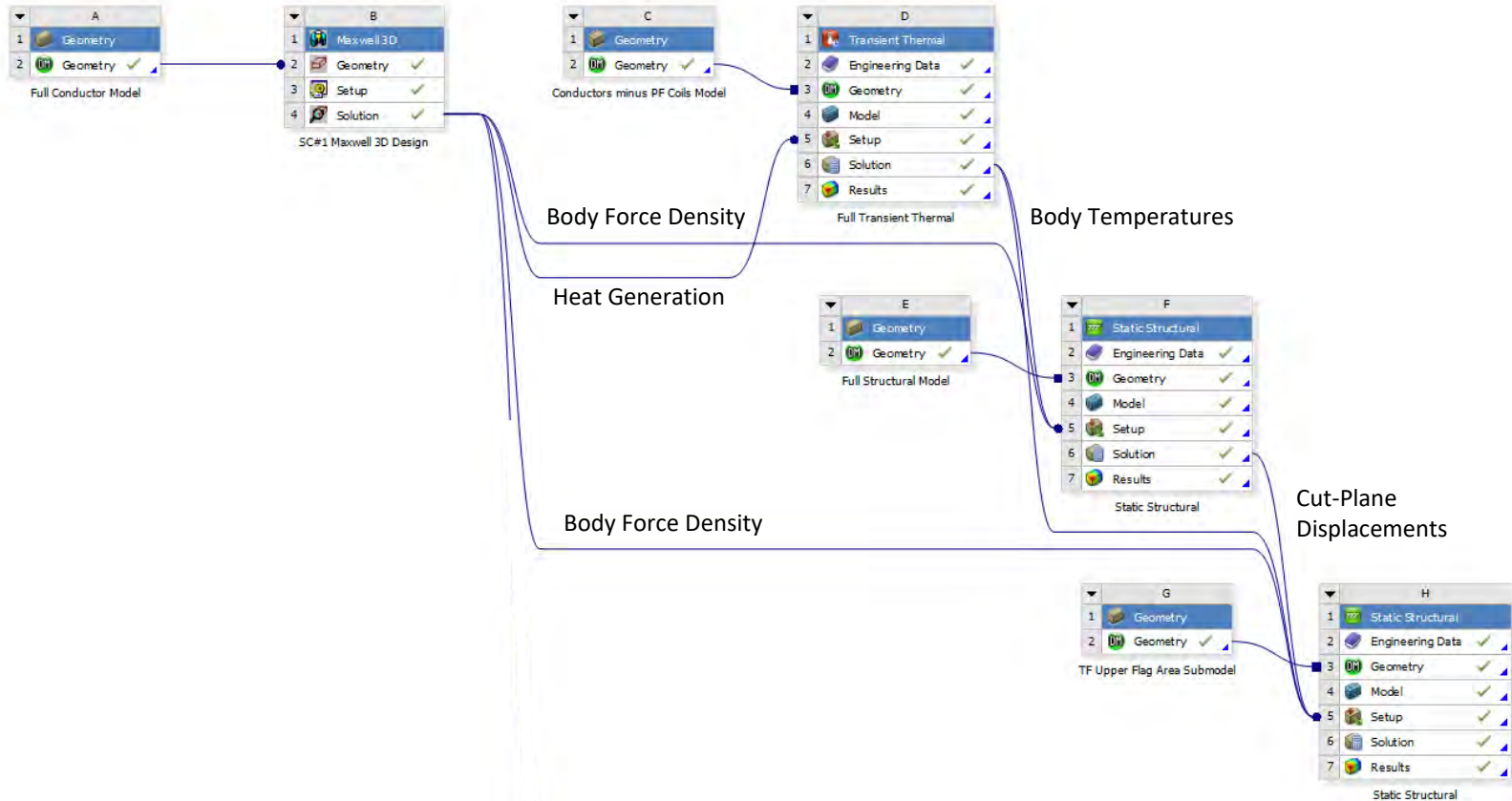

SolidWorks Cyclic Symmetric Conductor Model

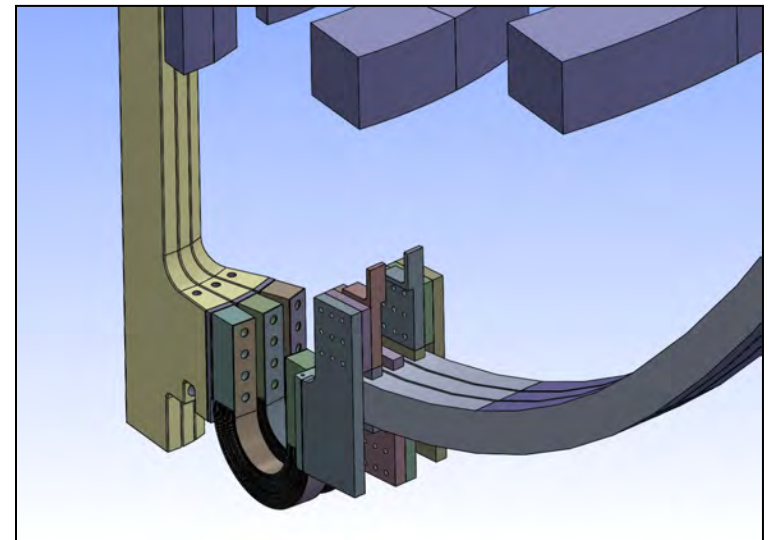
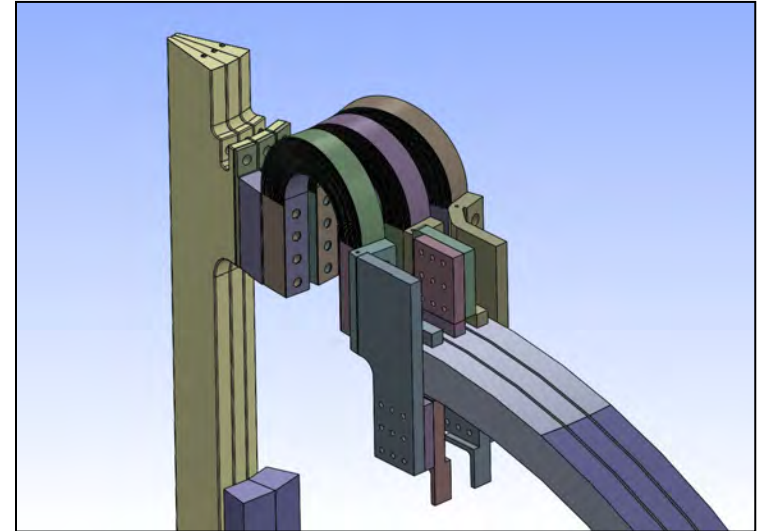
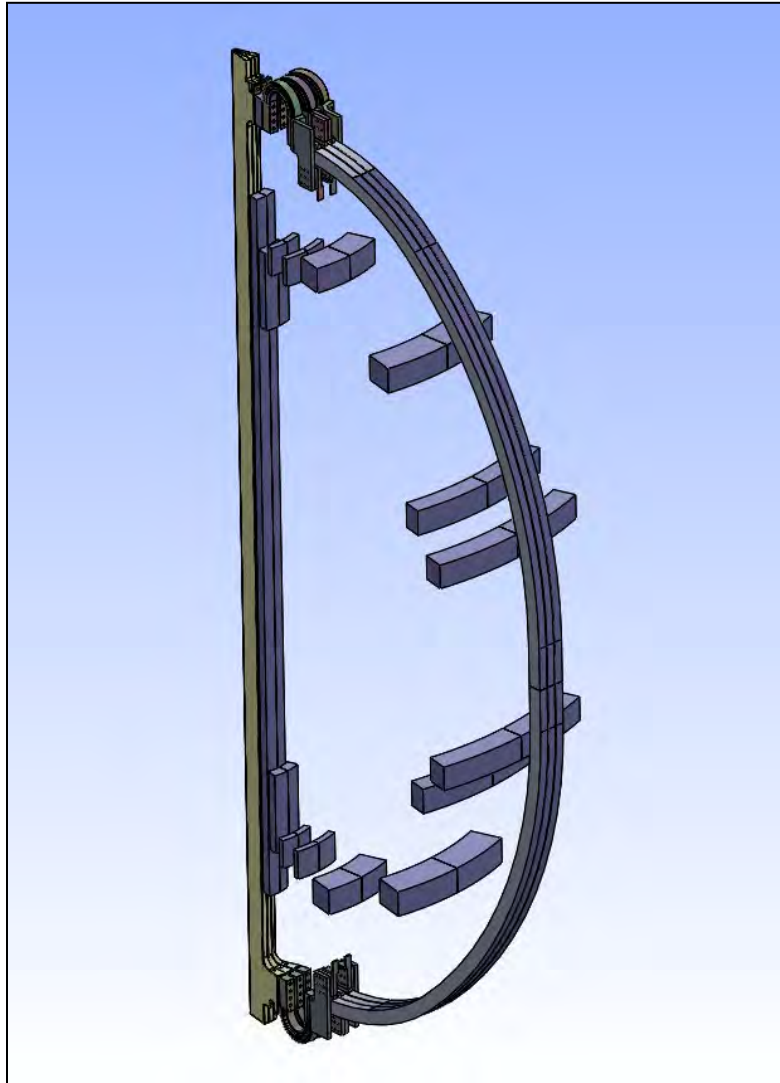

Maxwell Full Cyclic Symmetric Conductor Model

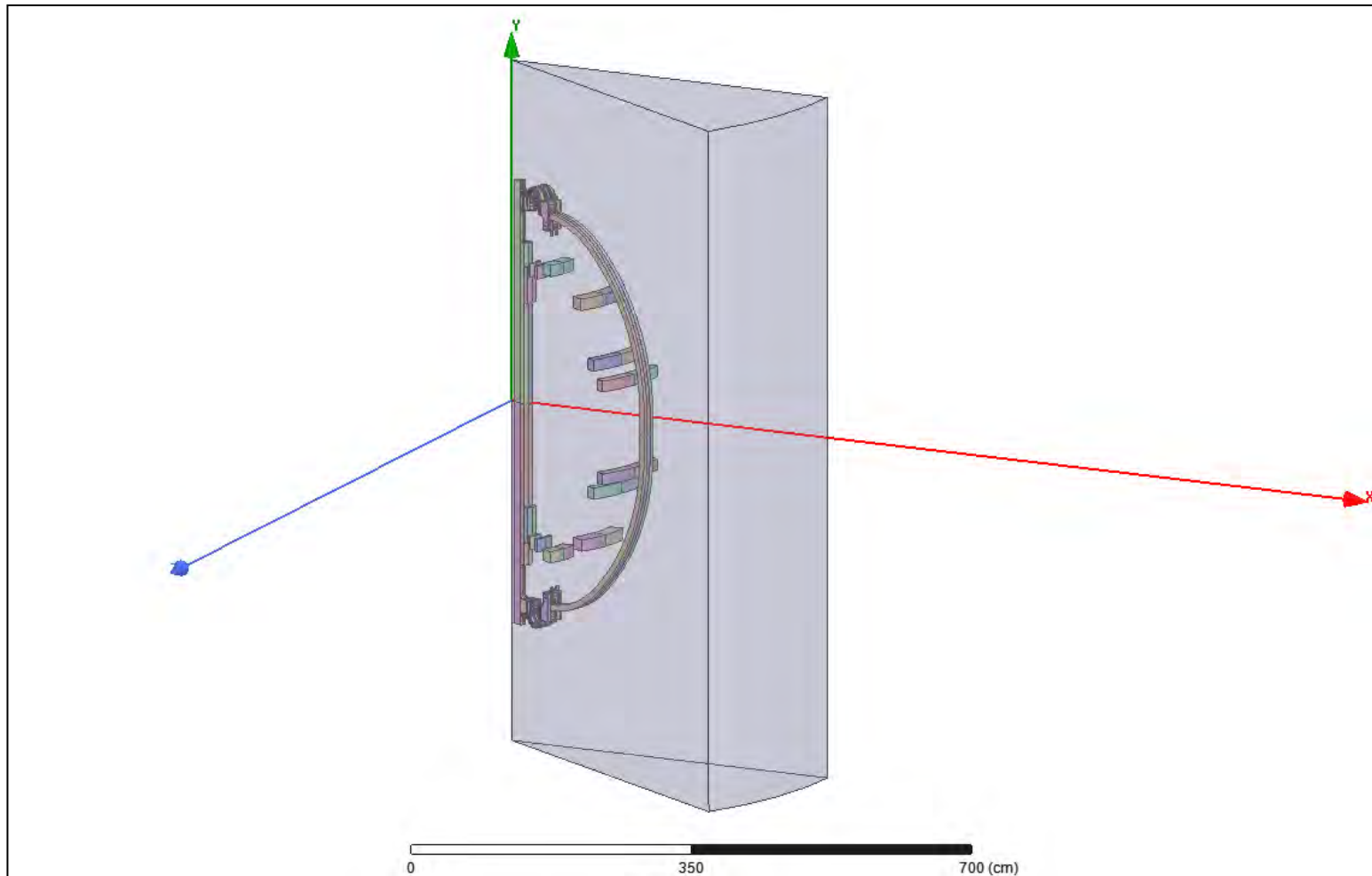

Maxwell Full Cyclic Symmetric Conductor Model: TF Conductor Details: Single Cooling Channel Filled for Master-Slave BC

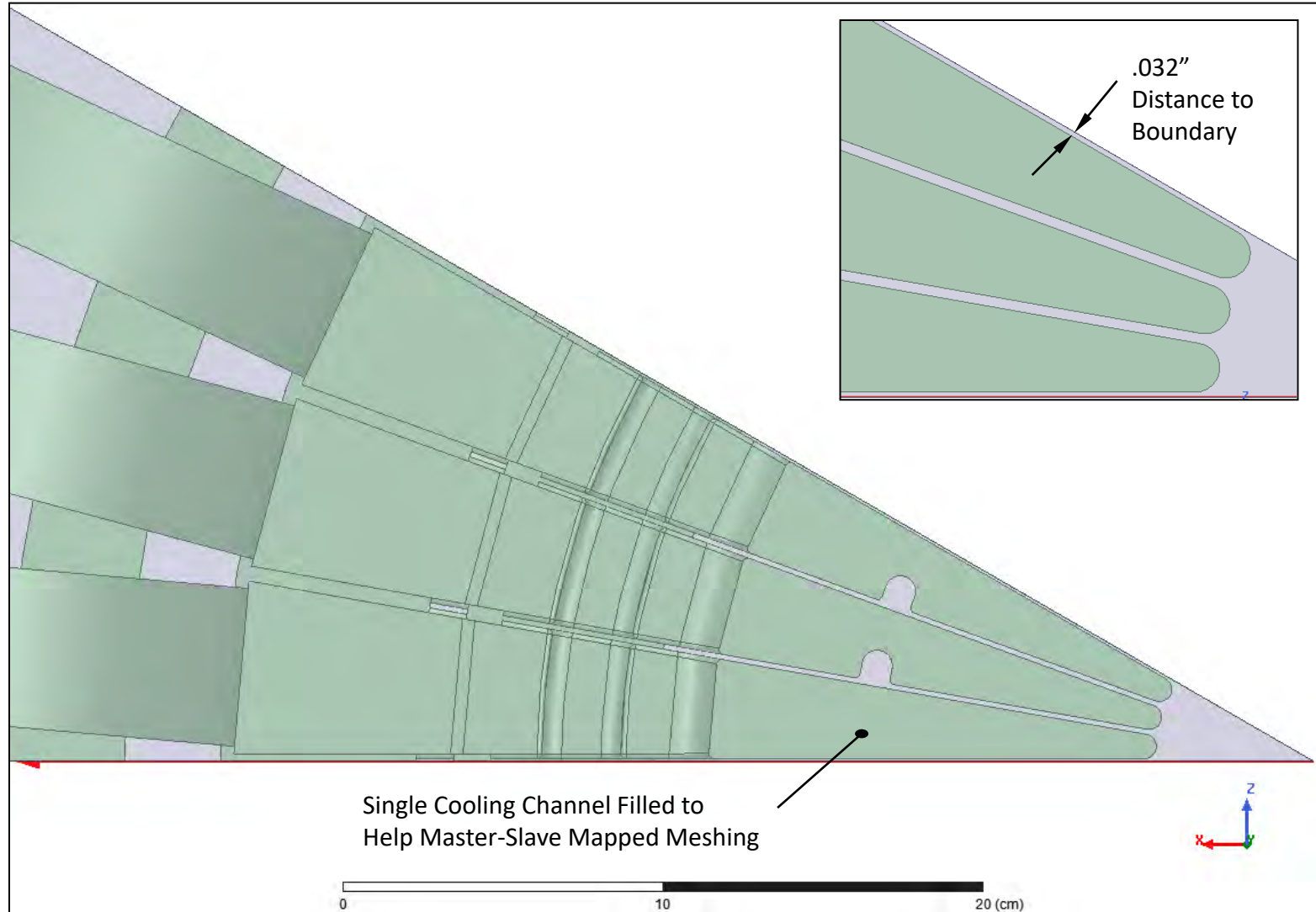

Maxwell Full Cyclic Symmetric Conductor Model: TF Conductor, Flag, and Flex Strap Details:

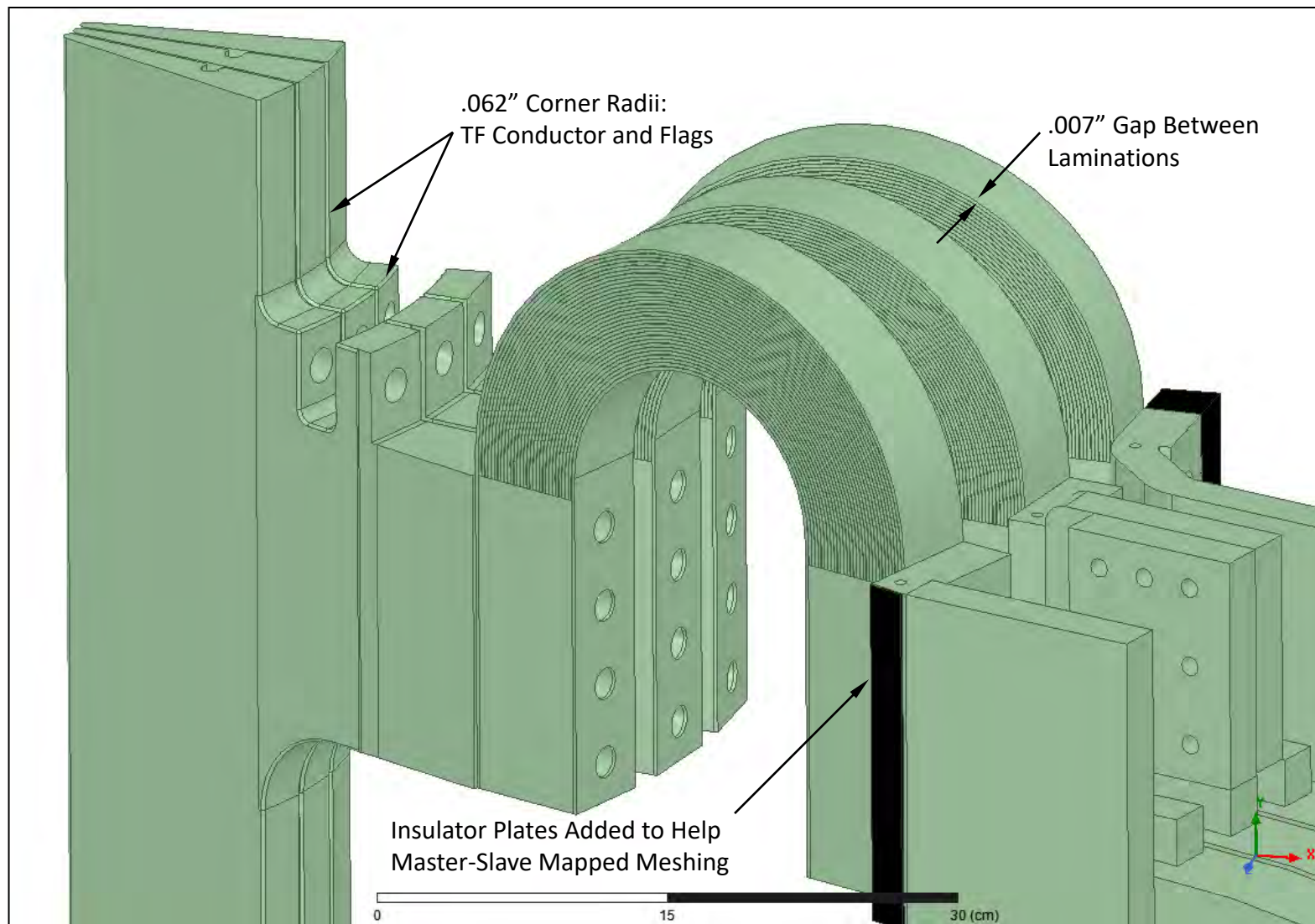

Maxwell Cyclic Symmetric Conductor Model: SC#1: Magnetic Flux Density

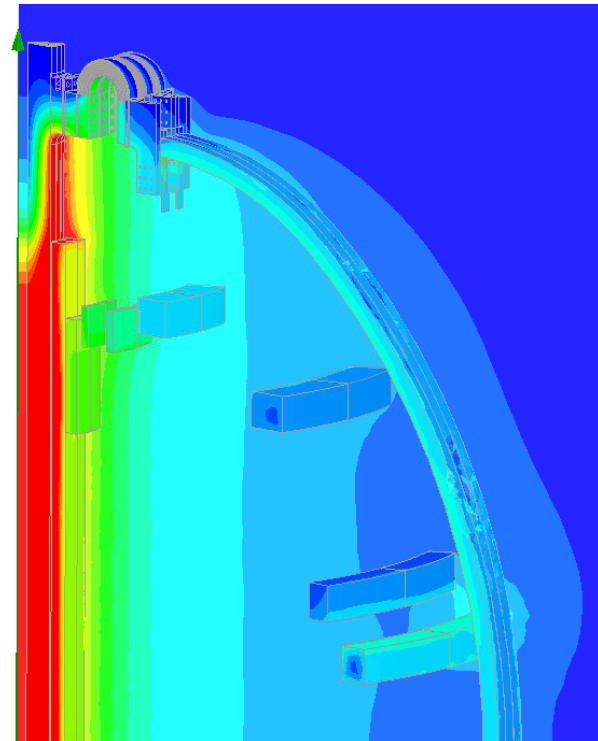
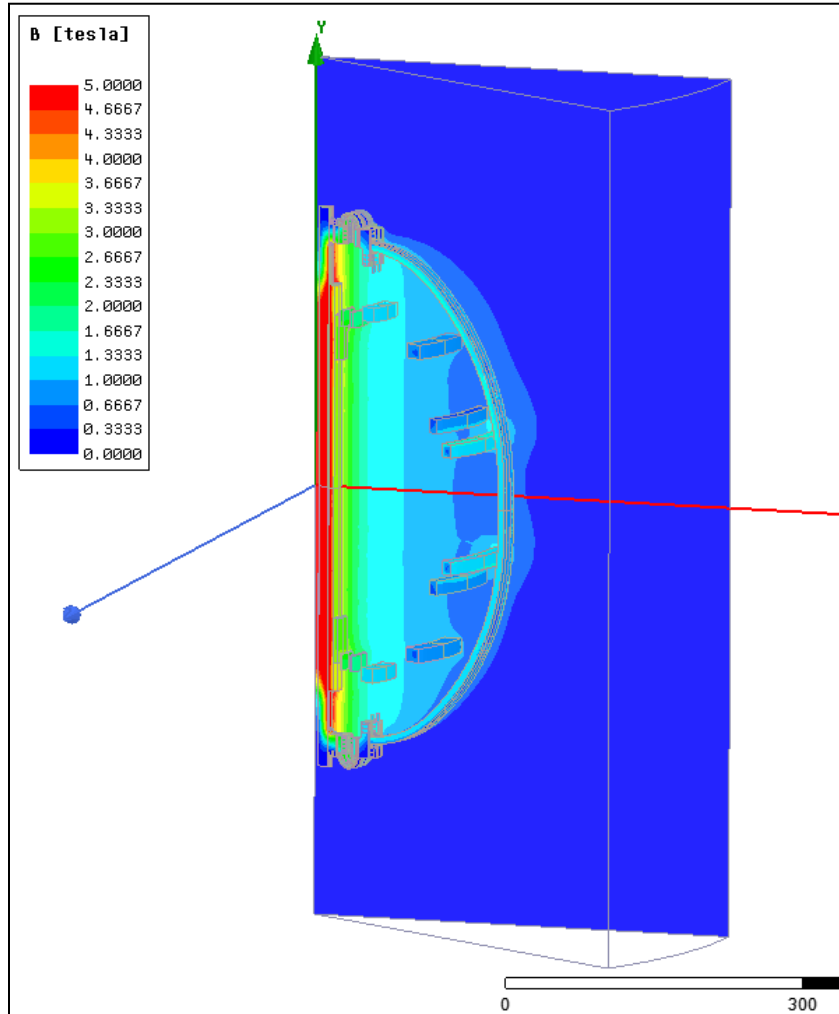

Maxwell Cyclic Symmetric Conductor Model: SC#1: Current Density

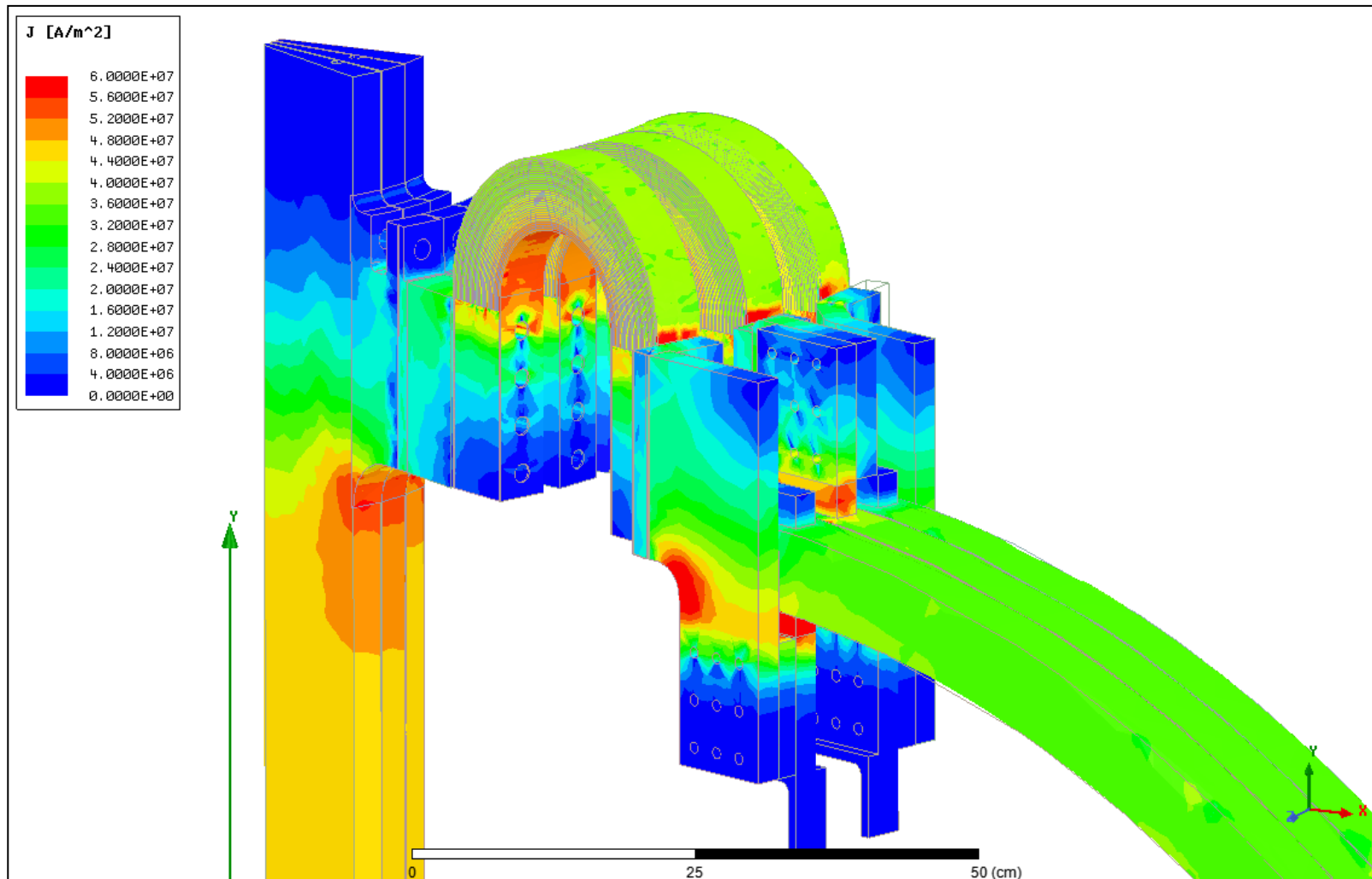

Maxwell Cyclic Symmetric Conductor Model: SC#1: Ohmic Loss

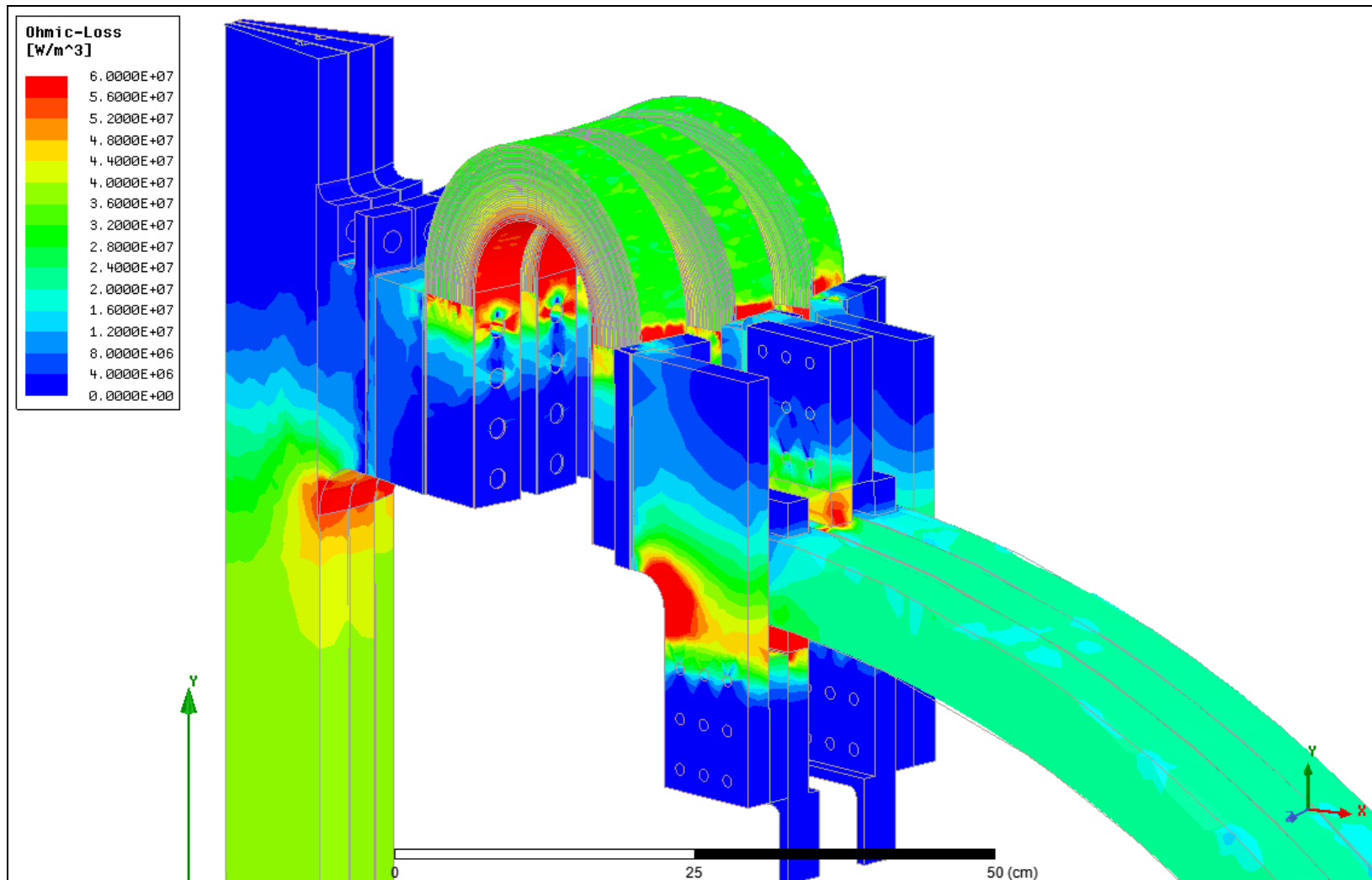

Static Structural Model: Body Force Density Import SC#1:

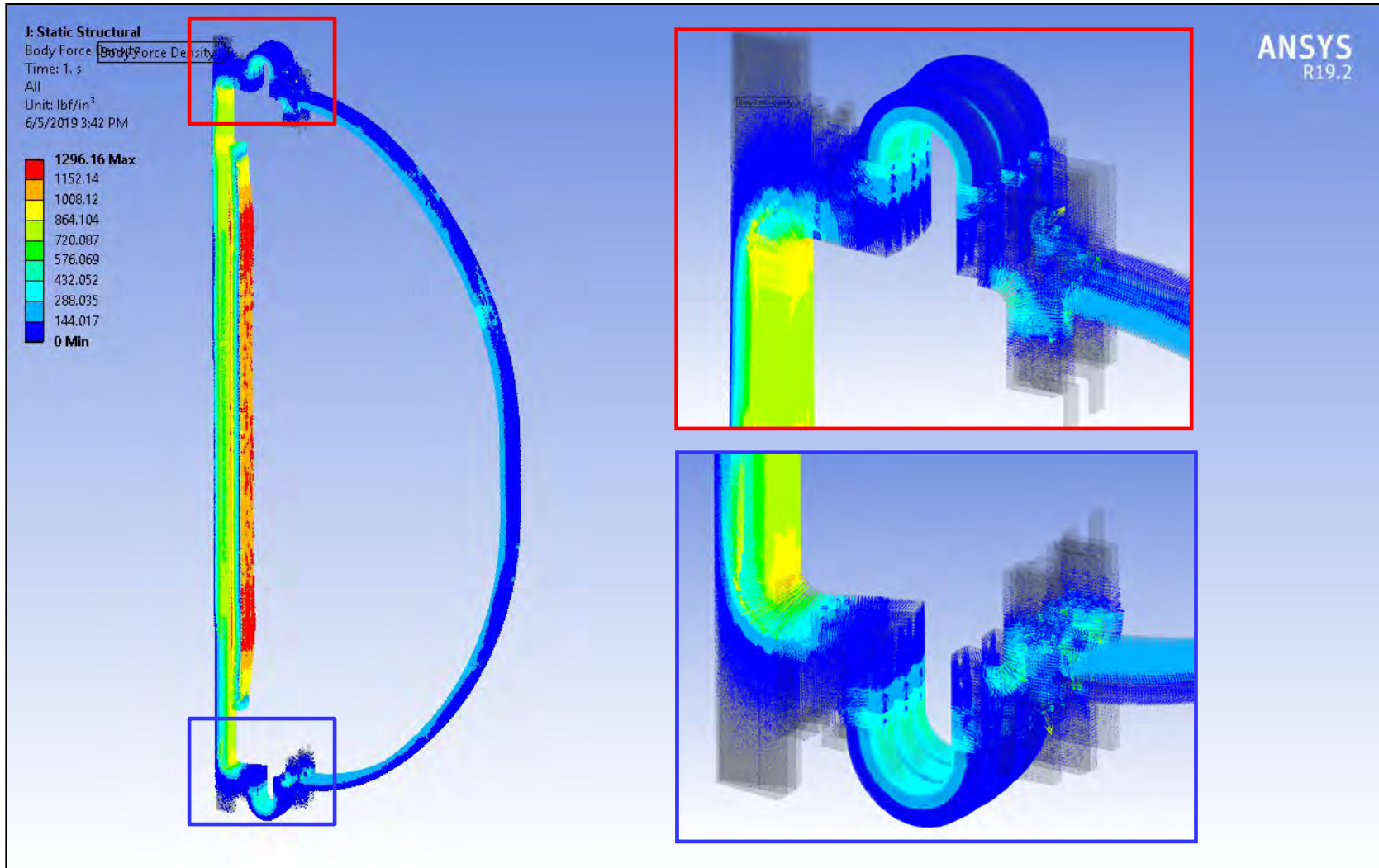

TF Bundle Turn-to-Turn Insulation Tape



Carolina Narrow Fabric Company

Technical Data Sheet

Part Number:	W1132205 1
Fiber:	S2G Fiberglass 9 micron fiber diameter
Weave Pattern	Plain
Width (inches):	1"
Thickness in Mils:	0.007"
Warp:	49 ends S2G 75 1/0 0.7Z (66 grams / 1000M)
Warp Density	19.3 yarns per Cm
Weft:	26 dbl picks S2G 150 1/0 (33 grams / 1000M)
Weft Density	10.2 x2 yarns per Cm
Treatment	Heat cleaned and silane treated
Pattern	Plain Weave

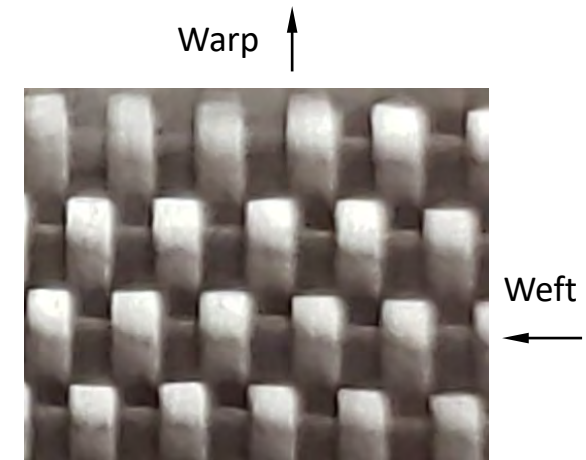

Tape weight = .0113 lbs/ yd
S2 glass volume fraction = 51%
Warp: 49 strands/ in;
408 filaments/ strand;
filament diameter = 9 microns;
65% of tape glass volume
Weft: 52 strands/ in;
204 filaments/ strand;
filament diameter = 9 microns;
35% of tape glass volume

$$E_{S2} = 87.5 \text{ Gpa}; v_{S2} = .23$$

TF Bundle Turn-to-Turn Insulation Stack-up

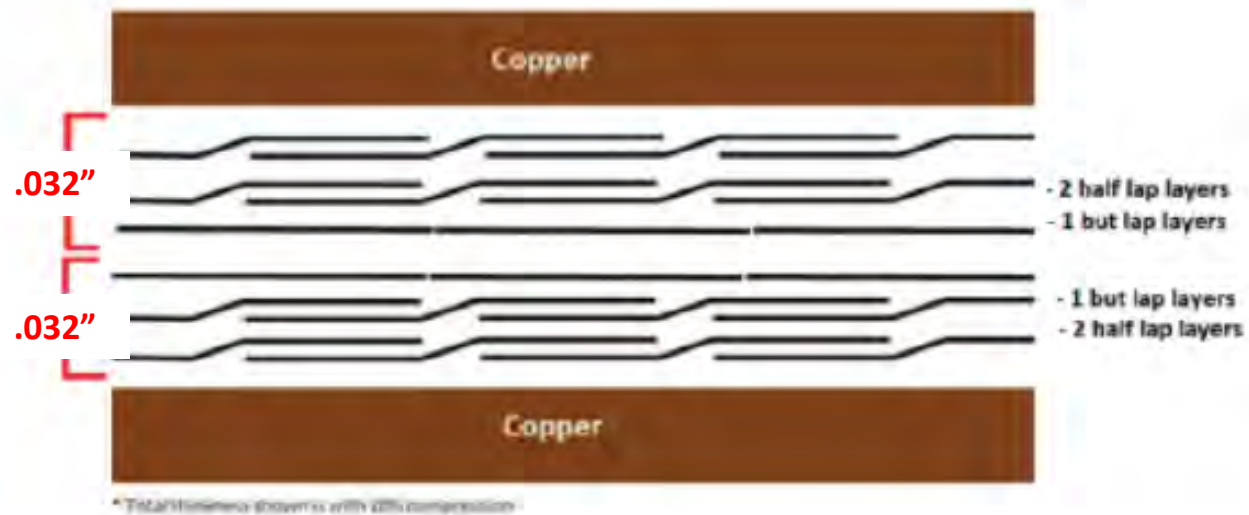



Figure 2 - As-built TF turn insulation

TF Bundle Turn-to-Turn Insulation: CTD-425 Resin

Test Results: "Performance Evaluation of Cyanate Ester Resin (CTD-403)", G.Voss, EURATOM/UKAEA Fusion Association/CTD



COMPOSITE TECHNOLOGY DEVELOPMENT, INC.
ENGINEERED MATERIAL SOLUTIONS



NANUQ™ CTD-425

Technical Data Summary

- **Blended EP/CE system**
 - CTD-425 is a two-part system with Epoxy (EP) and Cyanate Ester (CE) catalyst in part A and Cyanate Ester (CE) in part B
- **System mixing ratio**
 - Mix 60 parts A (EP) to 40 parts B (CE)
- **Processing**
 - Mixing/Processing Temperature: 45-60°C
- **Initial Viscosity and Potlife**

	At T=45°C	At T=50°C
Initial viscosity	90 mPa·s	70 mPa·s
Viscosity after 100 hours	150 mPa·s	150 mPa·s
- **Cure Profile**
 - Ramp slowly from processing temperature to 100°C (suggest > 2 hours)
 - 22 hour hold at 100°C; material should gel
 - Ramp slowly from 100°C to 170°C (suggest >3 hours)
 - 24 hour hold at 170°C
 - Cool down SLOWLY to room temperature (suggest > 6 hours)
- **T_g by DMA (from knee of storage modulus)**
 - 185°C

This information, while believed to be completely reliable, is not to be taken as warranty for which we assume legal responsibility. It is offered for consideration, investigation, and verification. Date Created: September 14, 2009 (Please disregard all previous versions of this data sheet)

2600 Campus Drive, Suite D | Lafayette, CO 80026 | 303-664-0394 | Fax: 303-664-0392 | www.CTD-Materials.com

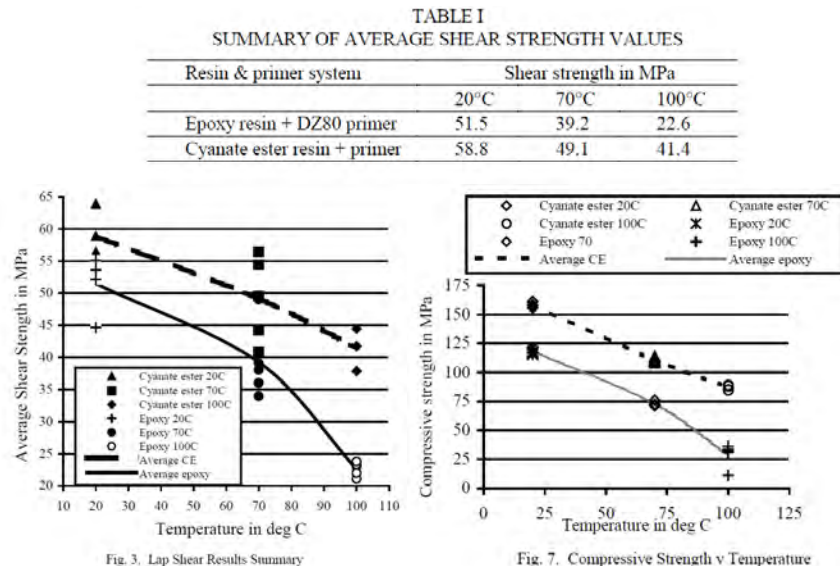

ANSYS Material Designer Insulation Properties Square Fabric Assumed (software restriction)

The screenshot displays the ANSYS Material Designer interface. The central focus is the 'Properties' table, which lists various material constants for a woven composite. The table is organized into sections: Engineering Constants, Density, Thermal Expansion Coefficient, Thermal Conductivity, and Fabric Fiber Angle. The 'Weaving type' is set to 'Plain', and the 'Algorithm' is 'Flattened Lenticular (high fiber volume fraction)'. The 3D model on the right shows a rectangular block with a green mesh and blue diagonal lines representing the fabric orientation.

Name	Value	Unit	P
Engineering Constants			
E1	1.8561E+10	Pa	<input type="checkbox"/>
E2	1.8561E+10	Pa	<input type="checkbox"/>
E3	9.2244E+09	Pa	<input type="checkbox"/>
G12	2.7708E+09	Pa	<input type="checkbox"/>
G23	3.1287E+09	Pa	<input type="checkbox"/>
G31	3.1289E+09	Pa	<input type="checkbox"/>
nu12	0.1083		<input type="checkbox"/>
nu13	0.41217		<input type="checkbox"/>
nu23	0.41216		<input type="checkbox"/>
Density			
rho	1632	kg m ⁻³	<input type="checkbox"/>
Thermal Expansion Coefficient			
aX	1.6797E-05	C ⁻¹	<input type="checkbox"/>
aY	1.6798E-05	C ⁻¹	<input type="checkbox"/>
aZ	4.4031E-05	C ⁻¹	<input type="checkbox"/>
Thermal Conductivity			
K1	0.57897	W m ⁻¹ ...	<input type="checkbox"/>
K2	0.57897	W m ⁻¹ ...	<input type="checkbox"/>
K3	0.532	W m ⁻¹ ...	<input type="checkbox"/>
Fabric Fiber Angle			
phi	0	degree	<input type="checkbox"/>

Results in general agreement with MathCAD calculation, which is also restricted to square fabric applications.

WiseTex Insulation Properties

Unsquare Fabric (software not restricted to square fabrics)

CNF Geometry model READY

Data | Geometry | 3D Image | Compression | In-plane deformation

Weave: plain

Yarns: Types (right click to edit)

Warp: Set

Warp 1: single 66 tex
Warp 2: single 66 tex

Welt: Set

Welt 1: double 2*33 66 tex
Welt 2: double 2*33 66 tex

Spacing, mm

1	0.518	Warp	1	0.980	Welt
2	0.518	Equal 0.518 mm	2	0.980	Equal 0.980 mm

Set equal to: 19.30 yarns/cm

Set equal to: 10.20 yarns/cm

Accept table 0.518 mm

Accept table 0.98 mm

Modelling options:

Crimp: Smart User defined (% of max) 50

Side crimp: Smart Maximum Neglected

Compute yarns compression in relaxed state

Fabric relaxation factor (0..1) 0

Points per crimp interval for 3D modelling 20

Current model built with: 20/0.00000

Precision level (relative error in crimp) 0

Unit cell size 2.0 x 1.0 x 0.220 mm

Areal density 198.4 g/sq.m

Porosity (inter-yarn) 41.0 %

Fibre volume fraction 36.6 %

Yarns:

	d1,mm	d2,mm	V1,%	L,mm	Crimp,%
warp 1	0.11	0.50	62.0	1.97	0.7
warp 2	0.11	0.50	62.0	1.97	0.7
welt 1	0.11	0.50	62.0	1.08	4.2
welt 2	0.11	0.50	62.0	1.08	4.2

Elastic properties, GPa	
1 = warp direction	laminate
VF	0.45
E1	29.4
E2	13.2
E3	8.3
G13	2.9
G23	2.8
G12	3
nu13	0.46
nu23	0.58
nu12	0.16
nu21	0.079

Results in good agreement with latest CTD and in-house measurements.

TF Coils Cooling Flow Path: Schematic

TF Coils Cooling Flow Path

IDENTICAL FOR ALL 36 COILS

OUTER TF COIL
LENGTH 409 IN.
ID 0.436 IN.

LENGTH 7.5 IN.
ID 0.25 IN.
2 PLACES

INNER TF COIL

LENGTH 237 IN.
ID 0.315 IN.

1/2" PARKER HOSE: MULTIPURPOSE OIL RESISTANT AIR & WATER HOSE, NONCONDUCTIVE, SERIES 7094, COLOR - RED
MAX. WORKING TEMP. 212°F,
MAX. WORKING PRESSURE 200 PSI TO 300 PSI

NOTE: THE LENGTH OF THE SUPPLY AND RETURN HOSES ARE FIELD DETERMINED.

NOTE: 1/2" PARKER HOSE: SERIES 7094 IS USED FOR ALL HOSES

LEGEND:

- THREADED CONNECTIONS
- ⊗ QUARTER TURN BALL VALVE
- ⊘ VENTURI FLOW ELEMENT
- RTD
- - - FLEXIBLE HOSE
- ||| FLOW DRIFICE

COMPILED BY: GENE RYAN
REVISIONS: NONE
NOT PERMITTED

CARD FILE NUMBER
ED5034922.DWG

REV	DATE	BY	CHK	APP	REASON	REV	DATE	BY	CHK	APP	REASON
1	08/02	GC	NA	GM	RE-DESIGN	1	07/13/18	GENS	REMAN	ADMS	
2	07/13	GENS	NA	GM	RE-DESIGN	2	07/13/18	GENS	CH	GM	
3	08/02	GC	NA	GM	RE-DESIGN	3	08/02/18	GENS	CH	GM	
REV	DATE	BY	CHK	APP	REASON	REV	DATE	BY	CHK	APP	REASON

APPROVED:
(Signature)
DATE: 12/13/2018

PLASMA PHYSICS LABORATORY
PRINCETON UNIVERSITY
NATIONAL SPHERICAL TORUS EXPERIMENT
CENTER STACK & COILS COOLING WATER SYSTEM
COOLING SYSTEM UPGRADE
P&ID

INSTR
B-804322
SHEET

TF Coils Cooling Flow Path: Local Heat Transfer Coeff.

Fluid116 Thermal/ Fluid Elements

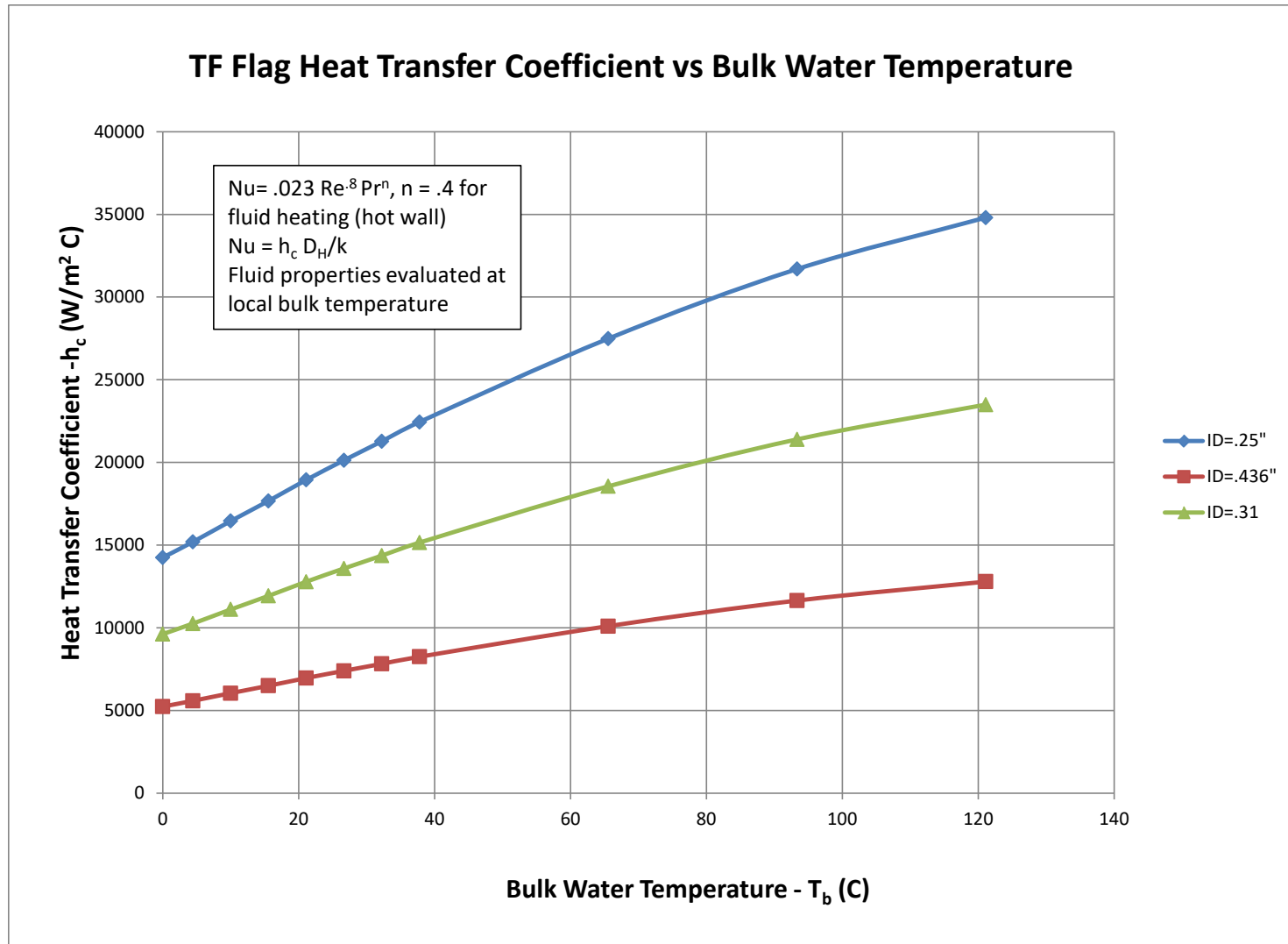

TF Coils Cooling Flow Path: Solid Model

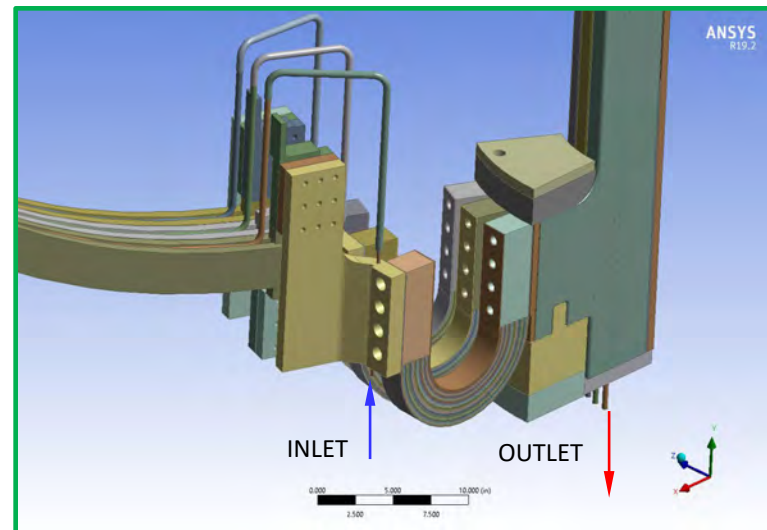
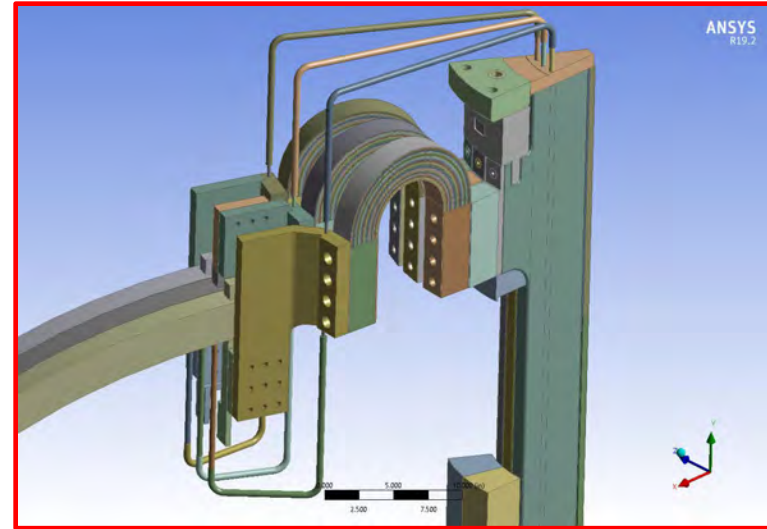
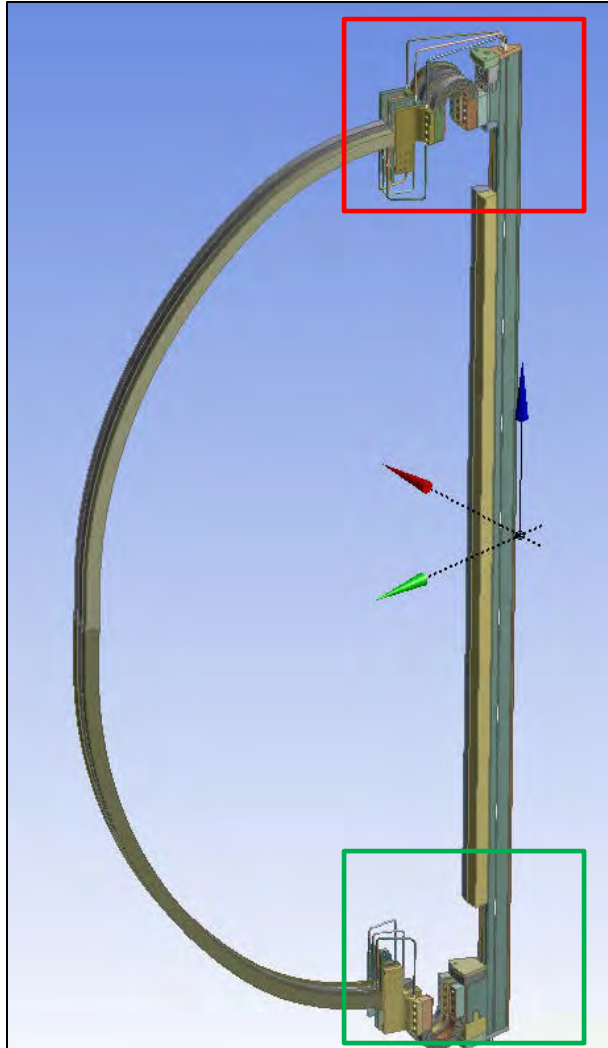

Transient Full Cyclic Symmetric Conductor Model: Upper Flag Area

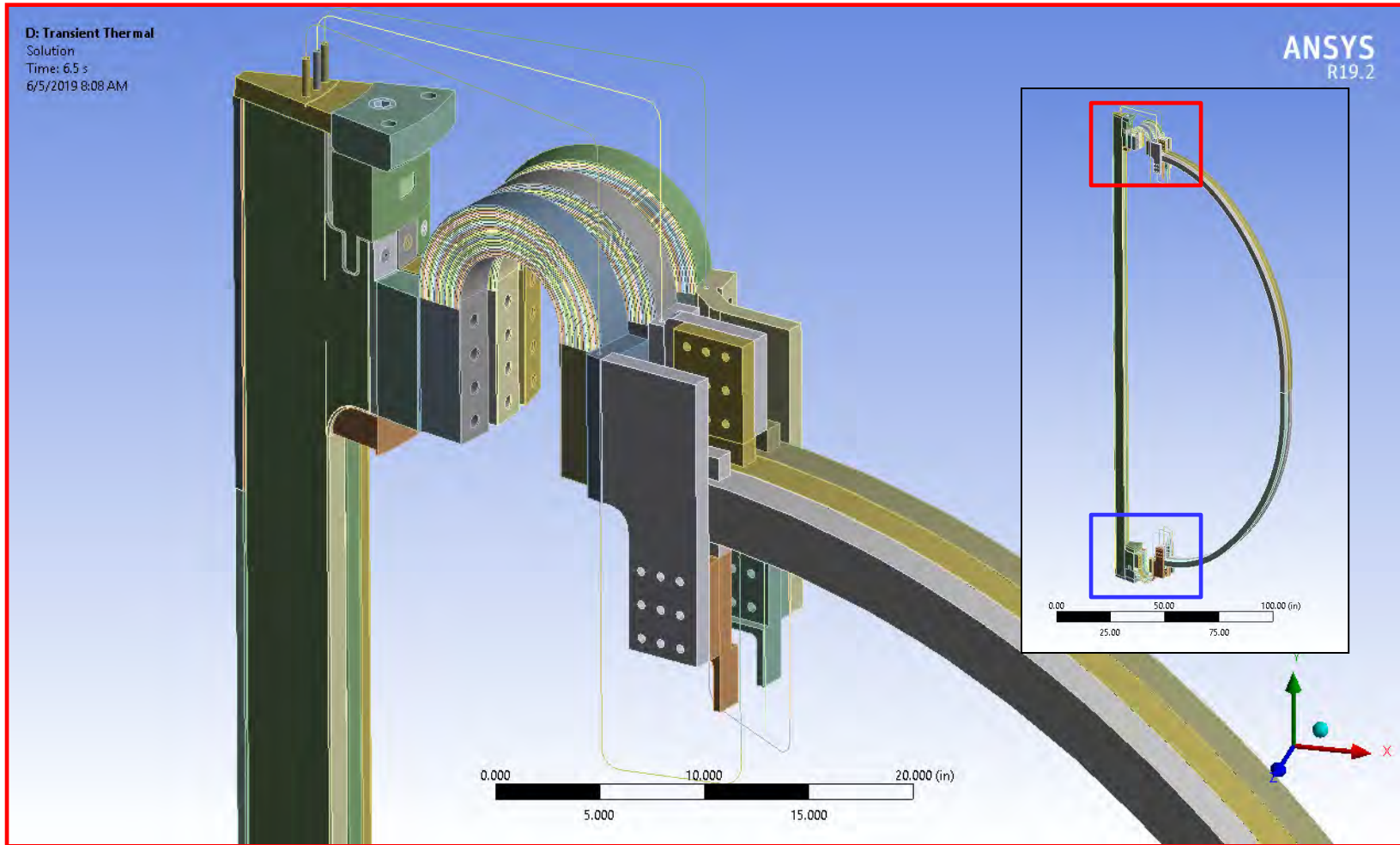

Transient Full Cyclic Symmetric Conductor Model: Lower Flag Area

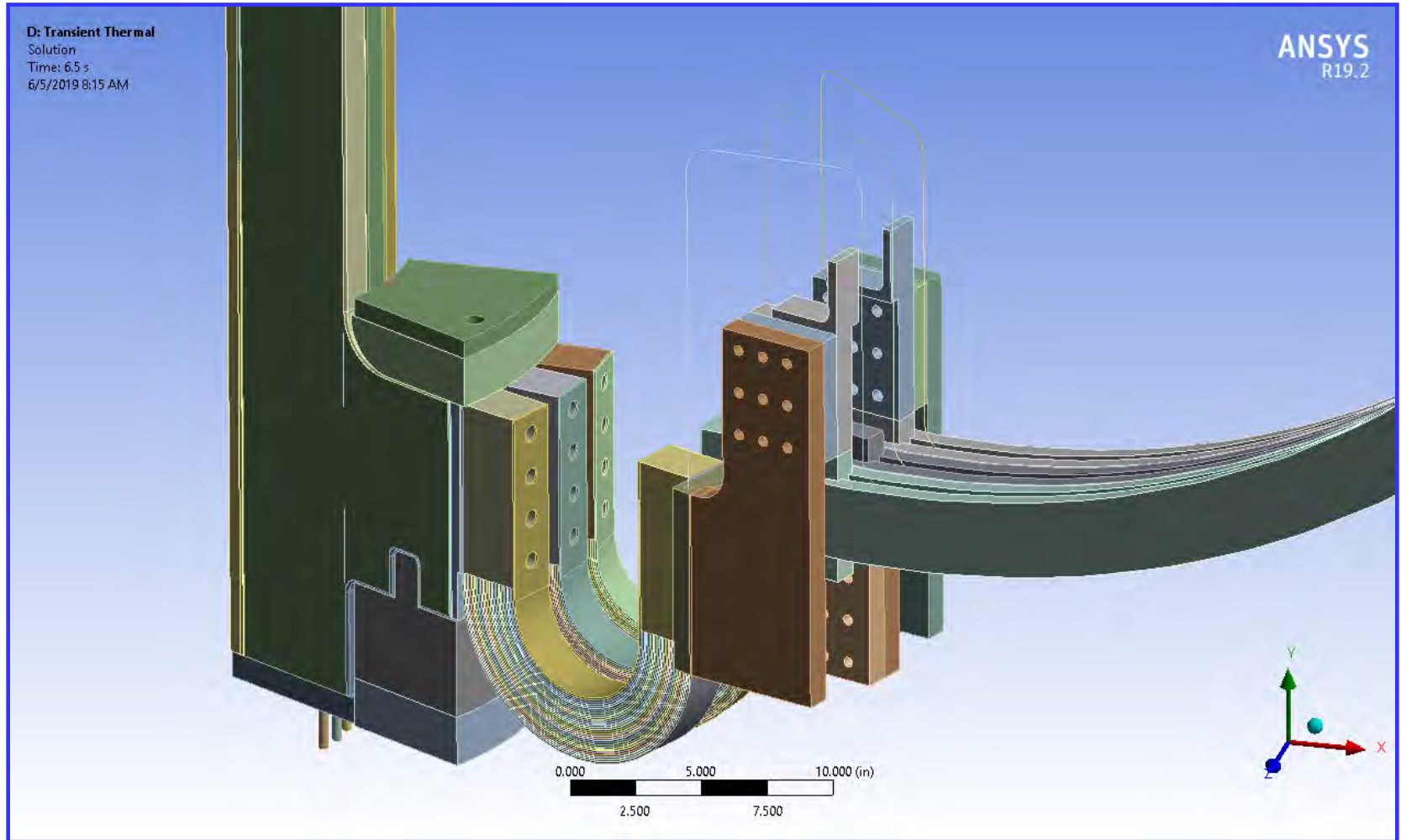

Transient Thermal Full Cyclic Sym. Conductor Model: Mesh

Nodes = 7.0E06; #Elements = 16.5E06; Default Element Size = .25"

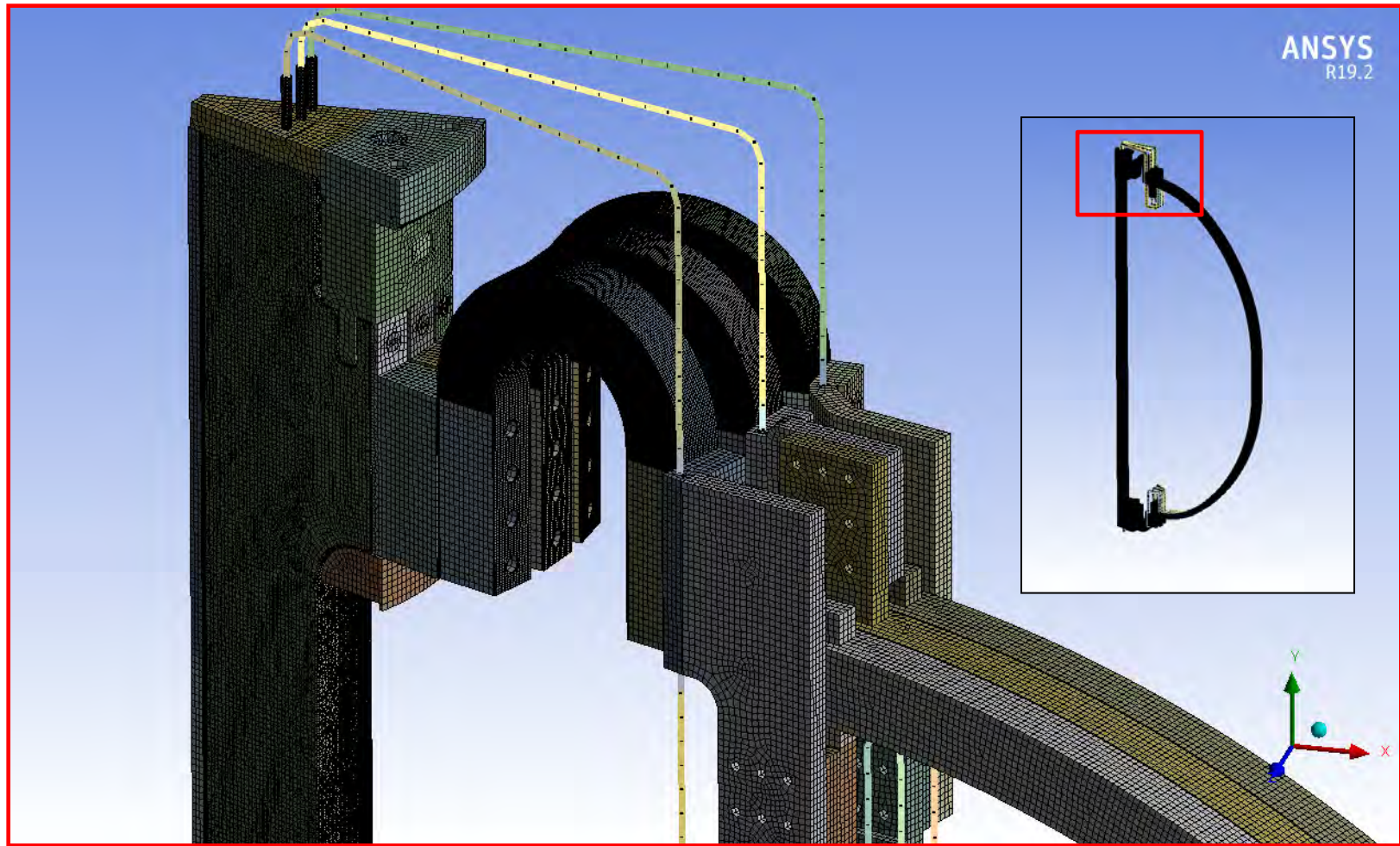

Transient Full Cyclic Symmetric Results: Water Temperature

SC#1: Inlet Water Temperature = 12 C; Water Flow Rate = 2.5 GPM/ Leg

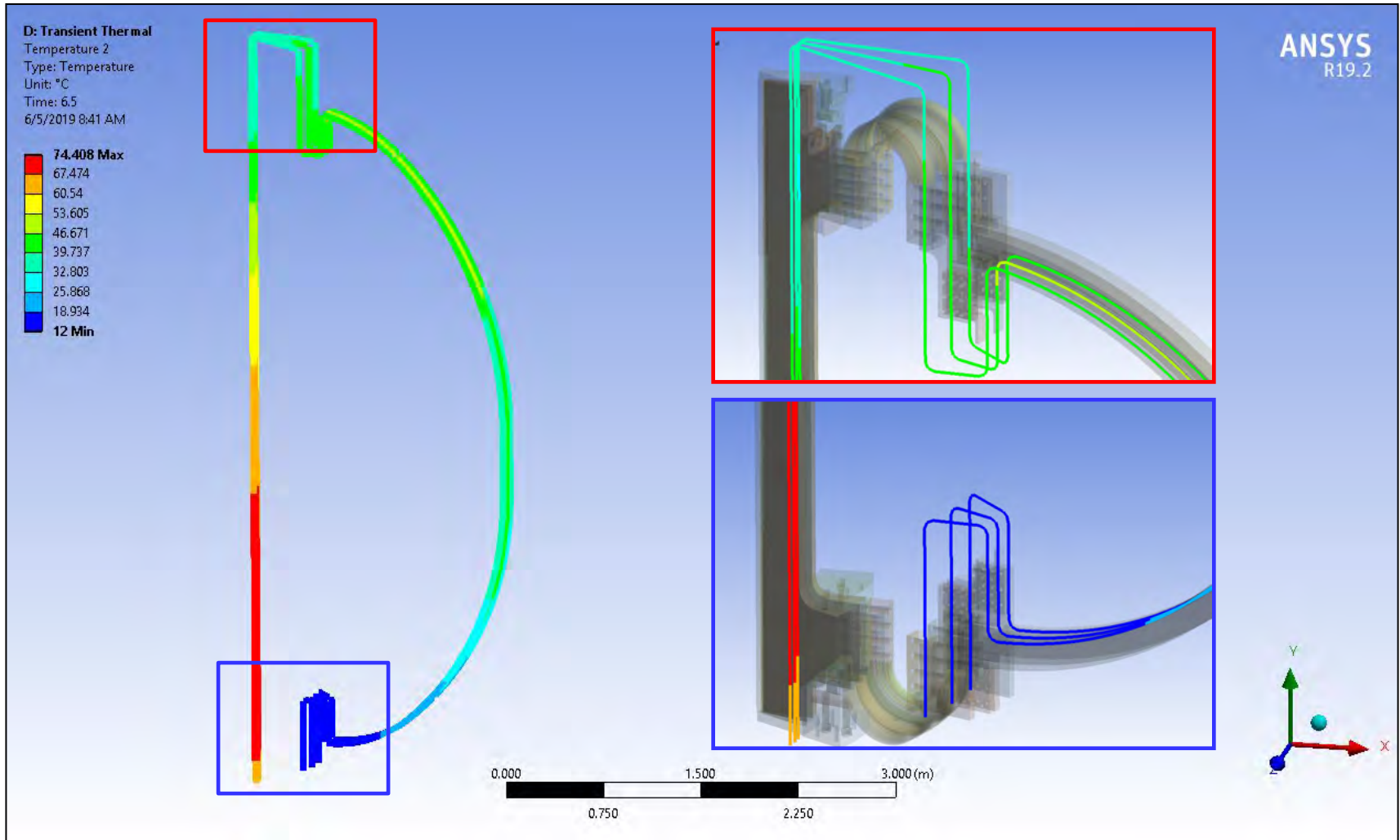

Transient Cyclic Symmetric Results: Temperature

SC#1: Upper Flag Area

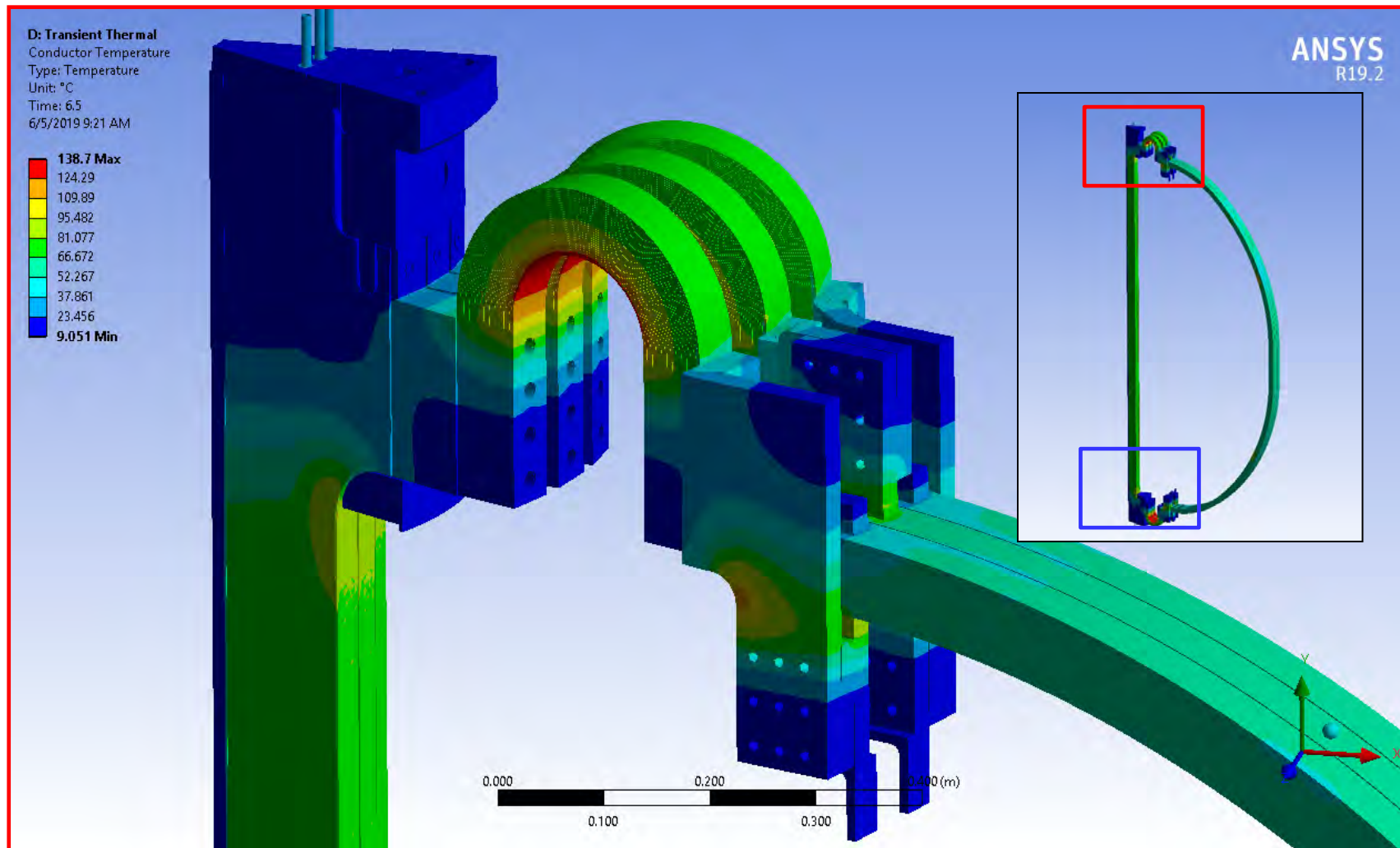

Transient Cyclic Symmetric Results: Temperature

SC#1: Lower Flag Area

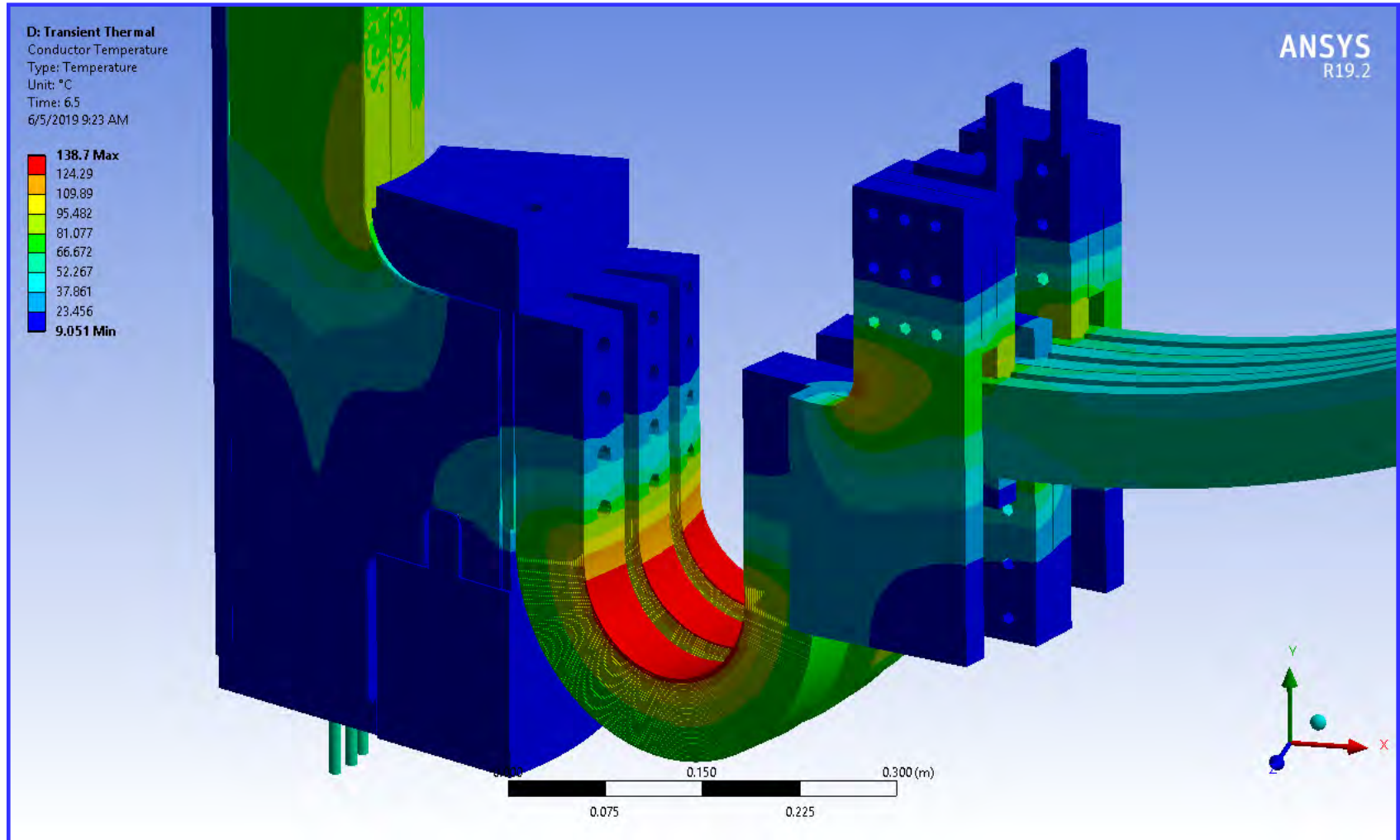

Transient Thermal Cyclic Sym. Results: Insulation Temperature

SC#1: Inlet Water Temperature = 12 C; Water Flow Rate = 2.5 GPM/ Leg

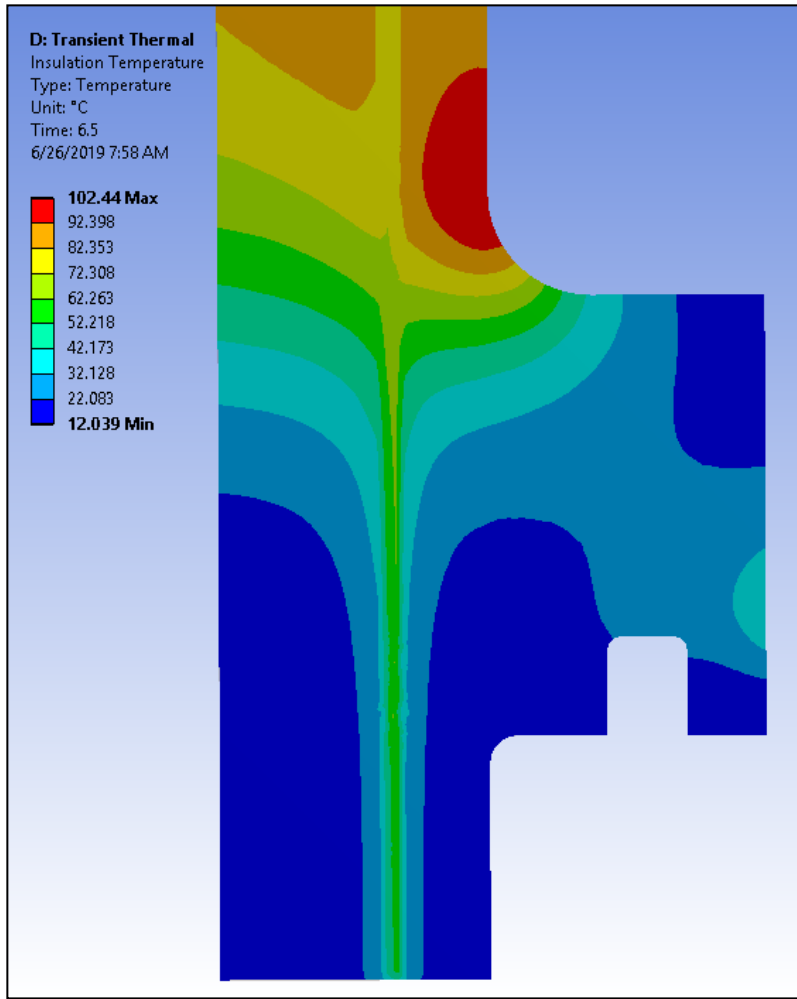

Lower Flag

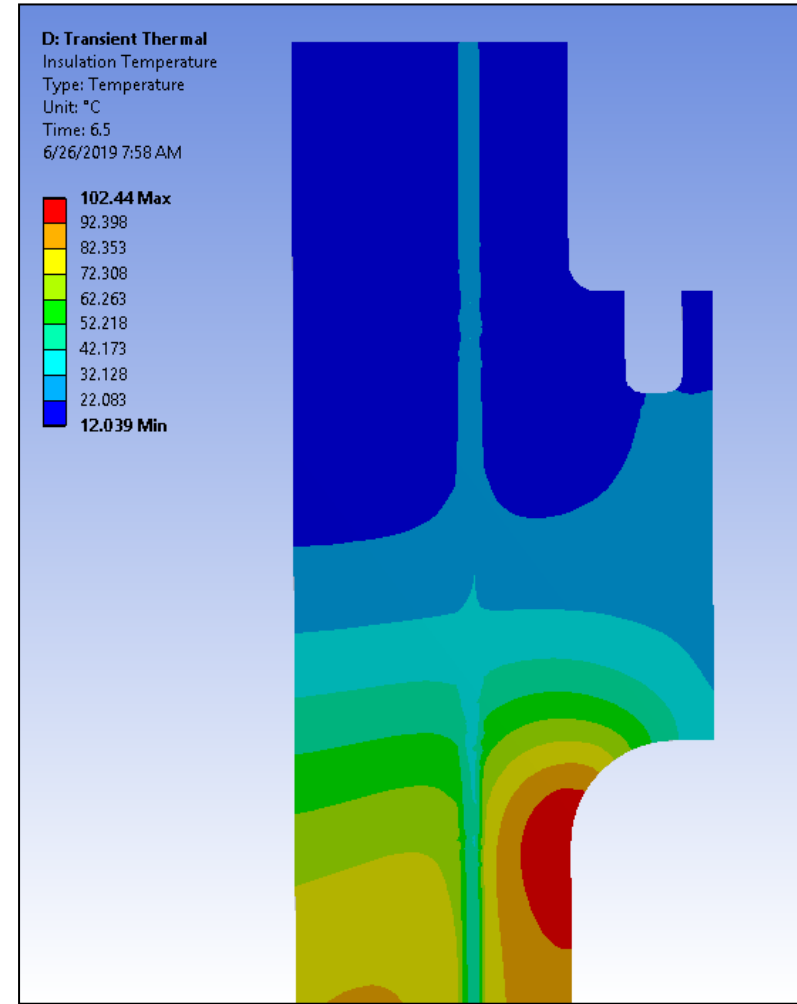

Upper Flag

DesignModeler 30° Cyclic Symmetric TF Conductor and Supports Model: Half of Full Umbrella and Lid Shown

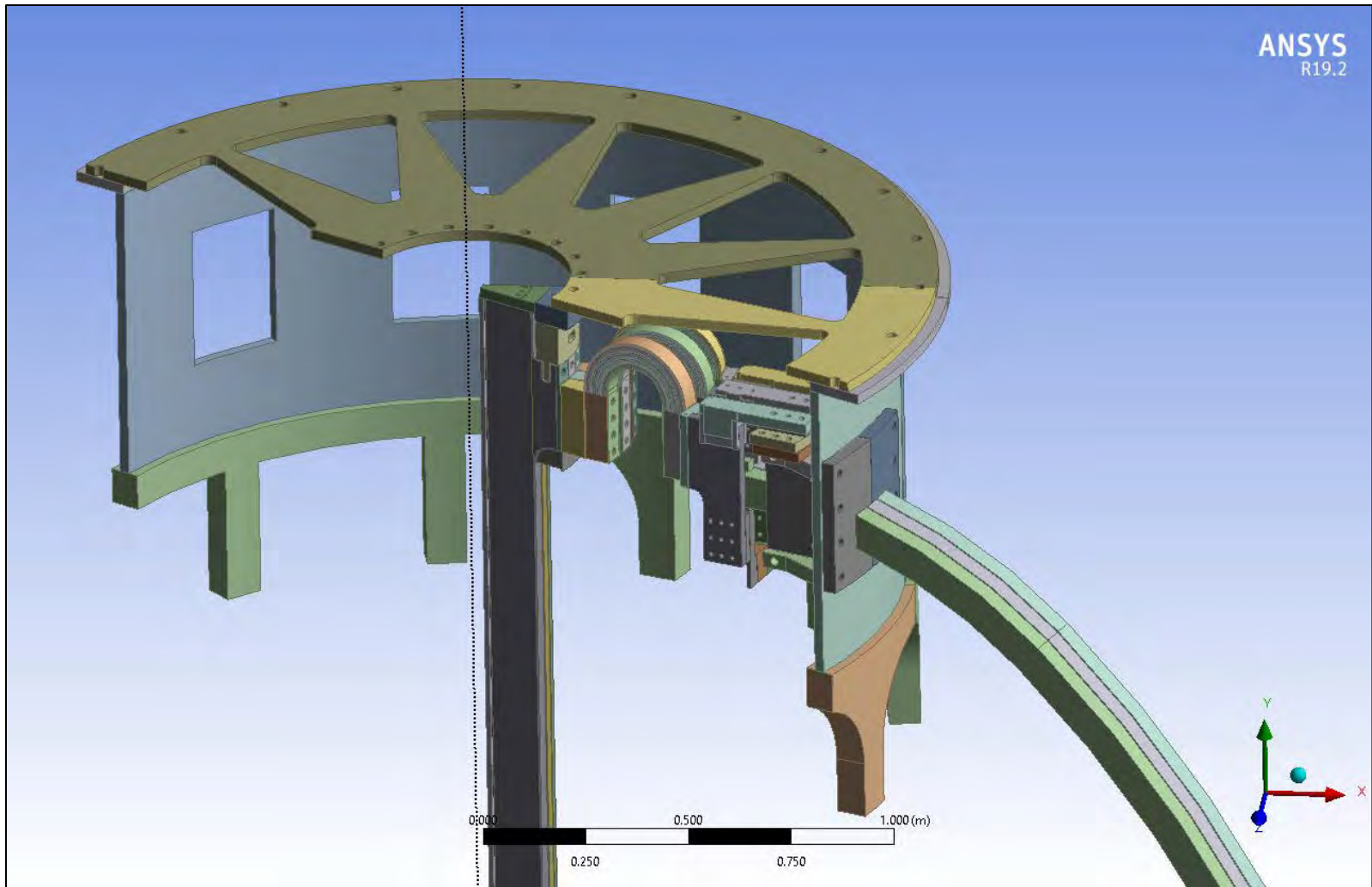

DesignModeler Cyclic Symmetric Conductors and Supports Model: Cyclic Symmetric Umbrella and Lid Segments

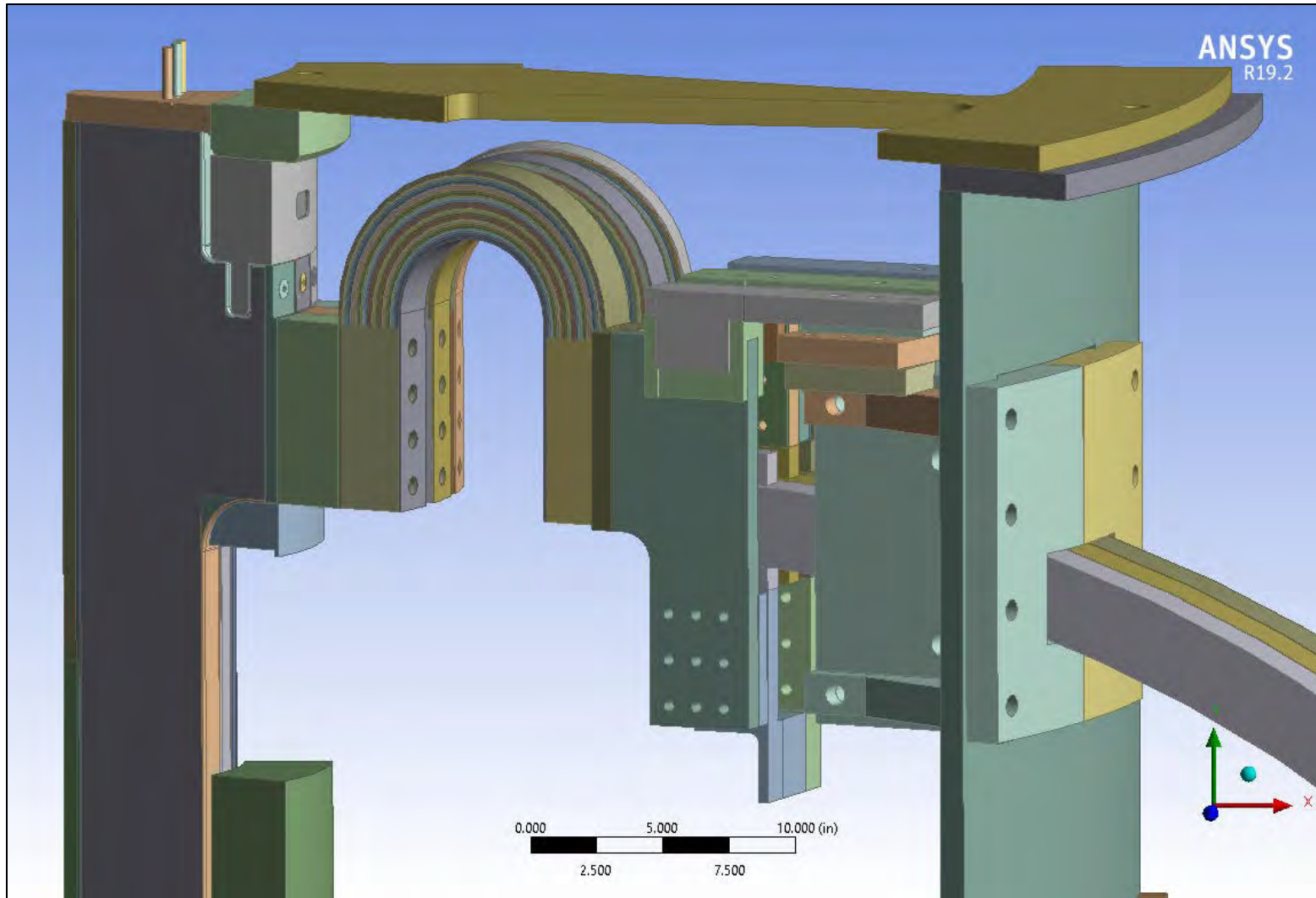

SolidWorks 30° Cyclic Symmetric Model: Present Model

Equivalent Stiffness Cyclic Skirt, OH Added

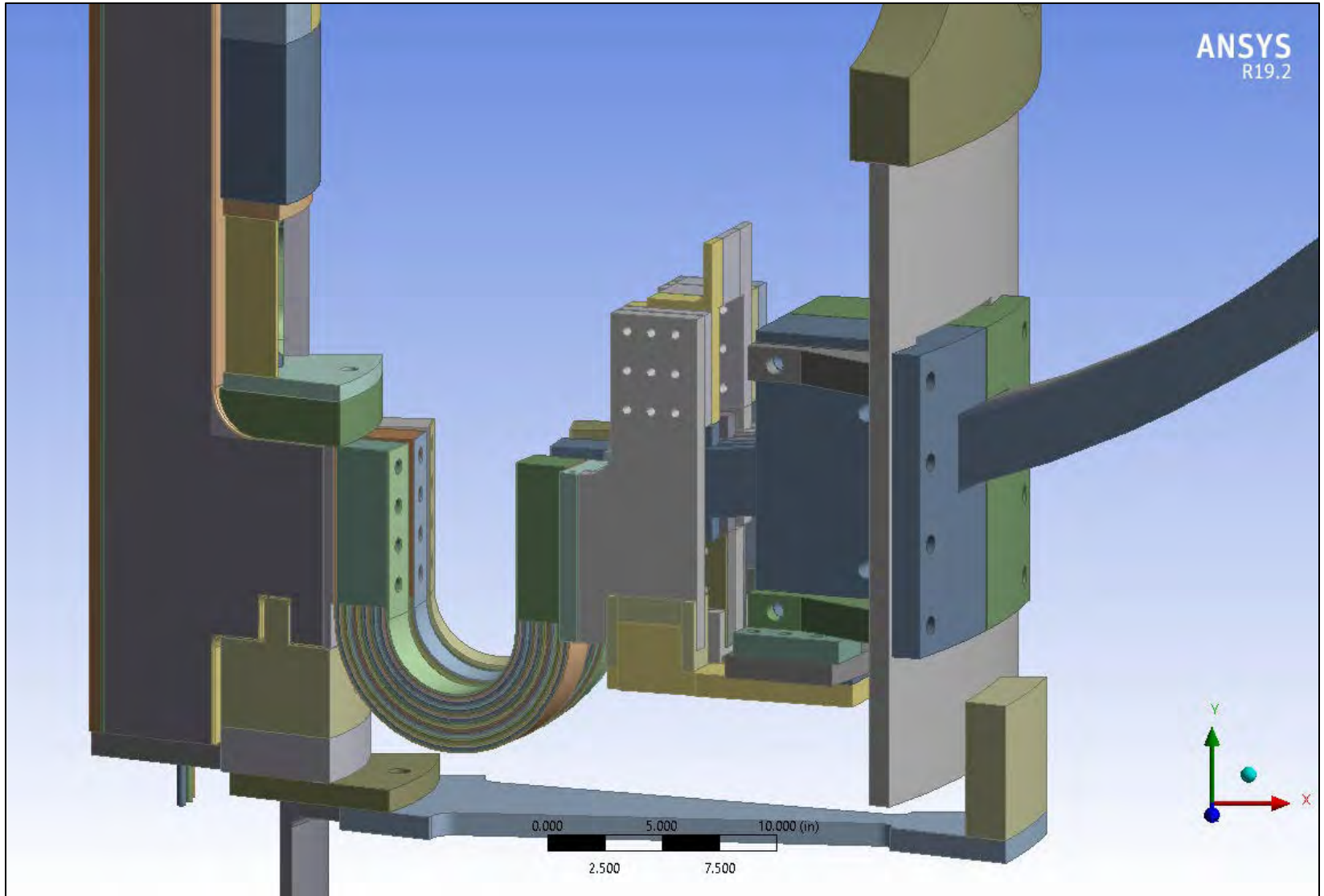

DesignModeler Cyclic Symmetric TF Conductors and Supports Model: Upper and Lower; PF Coils and Supports Not Included

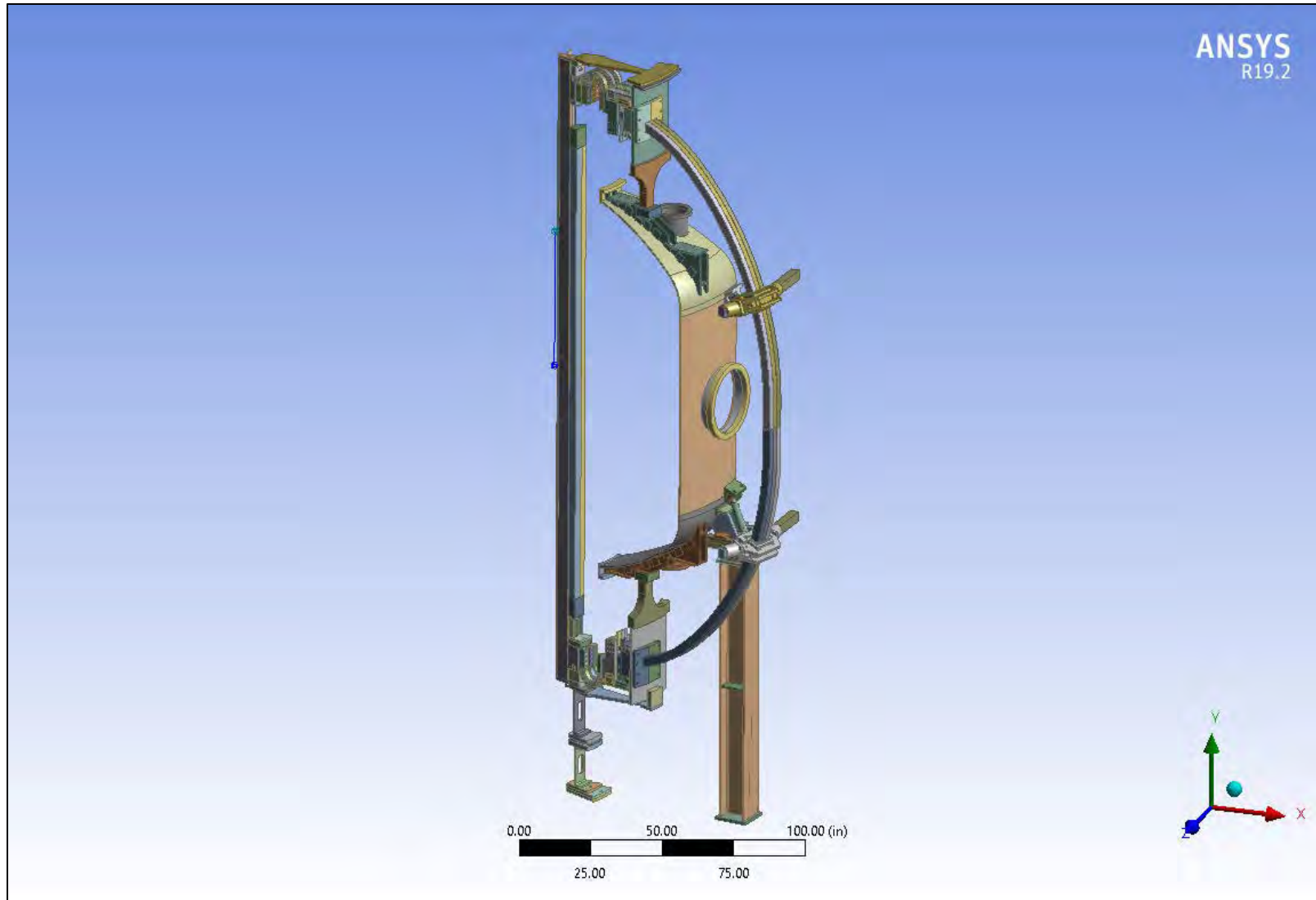

Static Structural Cyclic Symmetric TF Conductors and Supports Model: Materials

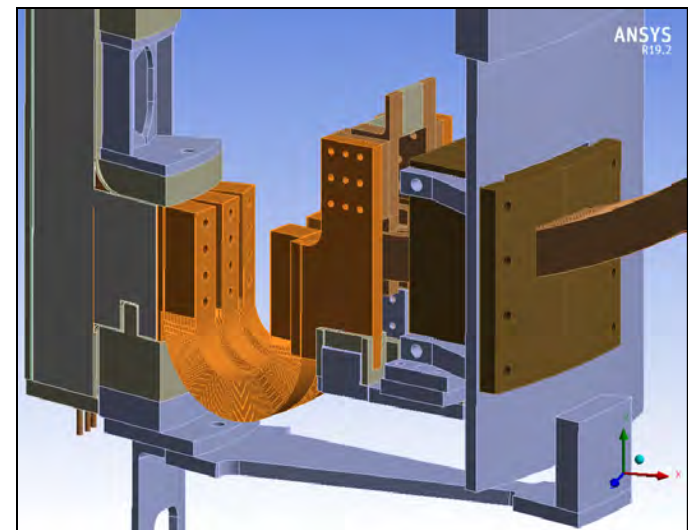
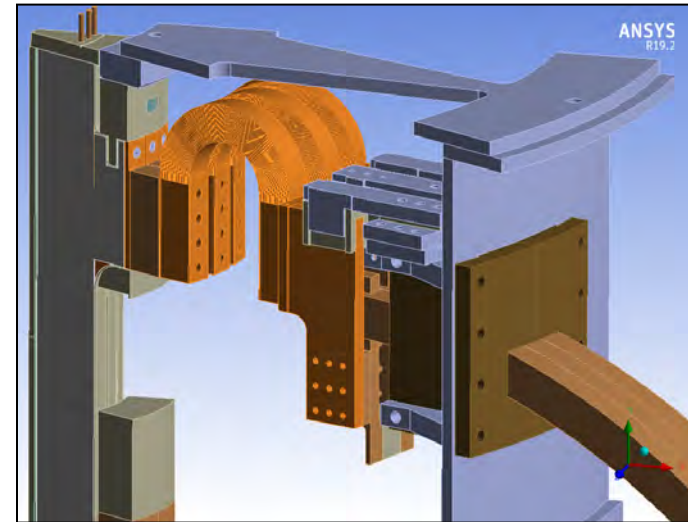
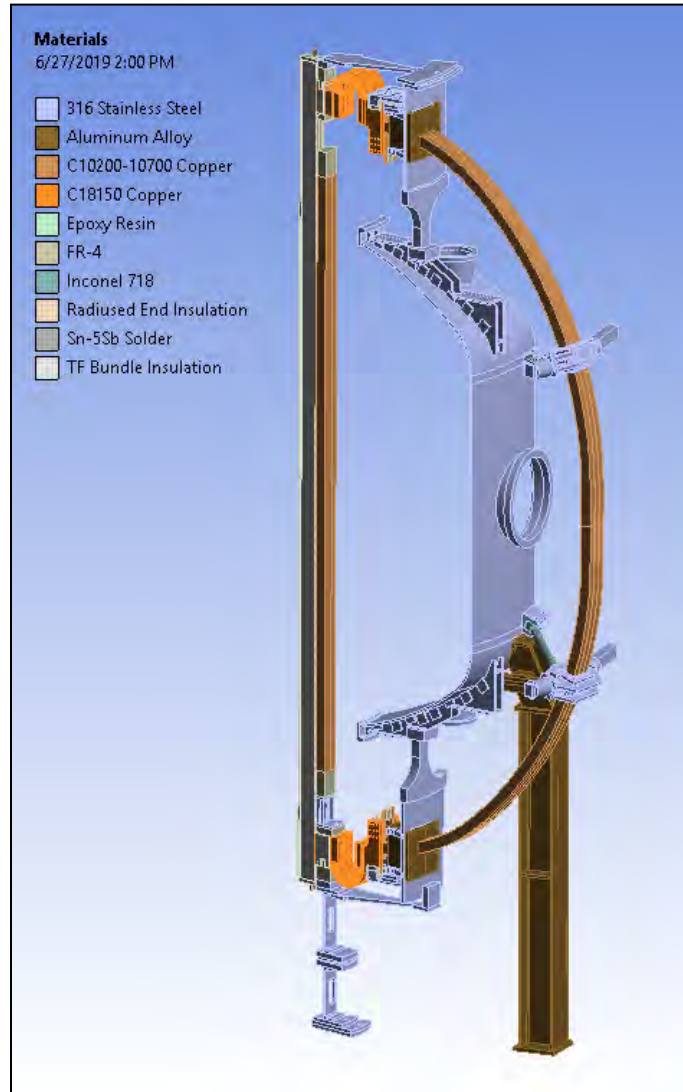

DesignModeler 360° TF Conductors and Supports Model: Visual Expansion of 30° Model; PF Coils Not Included

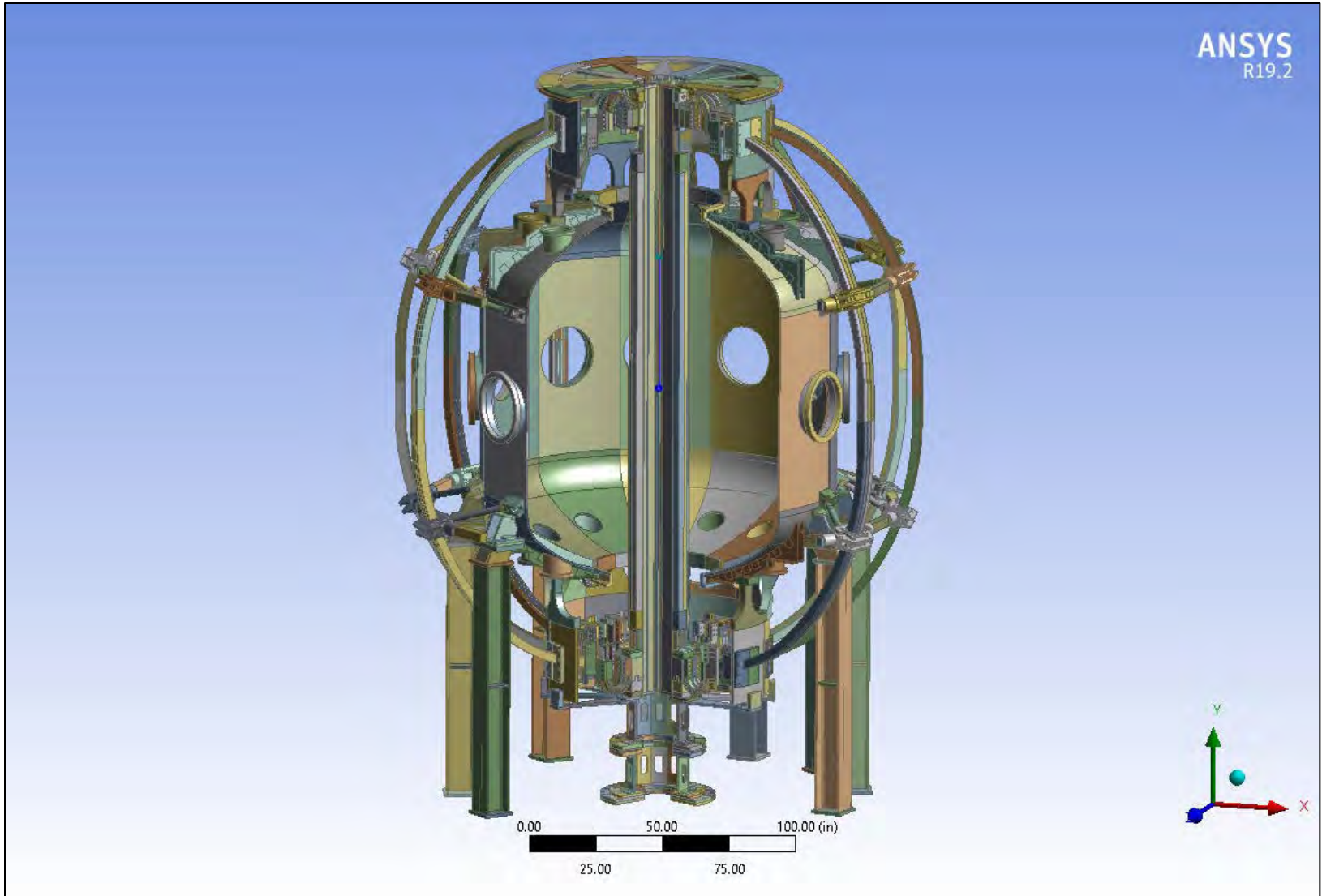

Static Structural Cyclic Sym. Model: Boundary Conditions

Fixed Constraints; Gravity; Applied Forces

ANSYS
R19.2

H: Static Structural
Static Structural
Time: 1. s
6/27/2019 4:19 PM

- A** Lower Flag OH Preload + CSC_Inner PFs Weight Force: 2476. lbf
- B** Upper Flag OH Preload Force: 2083. lbf
- C** Standard Earth Gravity: 386.09 in/s²
- D** Pedestal Base Fixed Support
- E** Vessel Support Leg Fixed Support

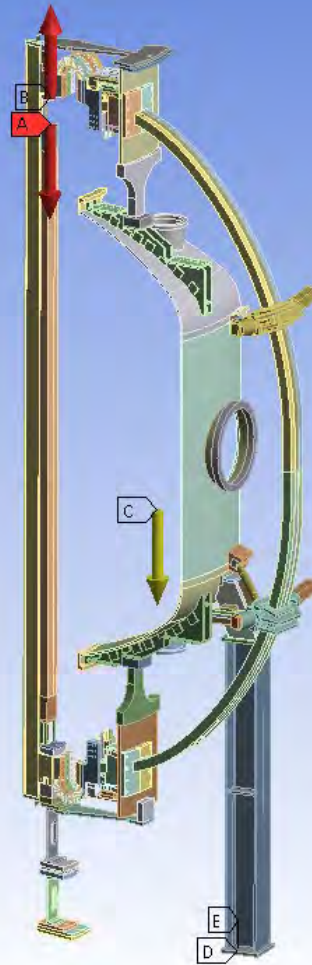

Lower Flag Combined Applied Force (lbf)

CSC	PF1AU/L	PF1BU/L	OH Preload	Total	Total/12
1889	2236	592	25,000	29717	2476



Static Structural Cyclic Sym. Model: Boundary Conditions Applied Temperature

ANSYS
R19.2

H: Static Structural

Ambient Temperature Thermal Condition

Time: 1. s

6/27/2019 11:37 AM

 Ambient Temperature Thermal Condition: 51. °C

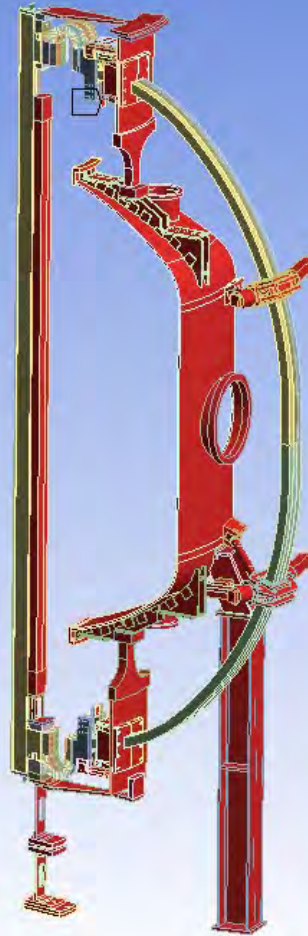

Static Structural Cyclic Sym. Model: Imported Loads Body Temperature (t =6.5 s, End-of-Flat Top)

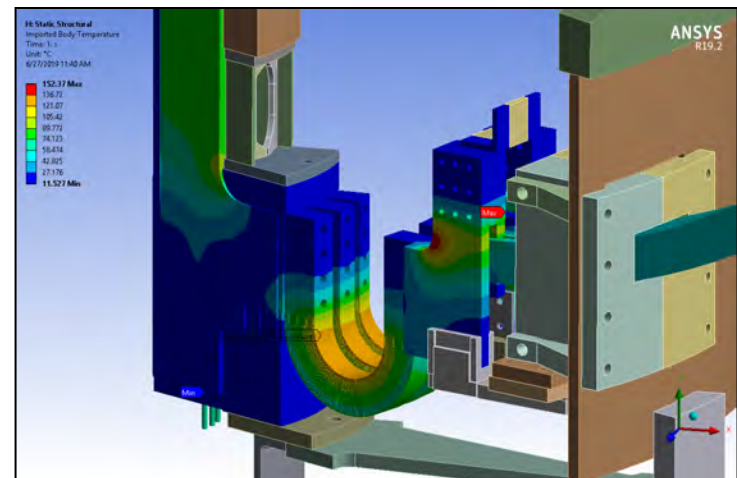
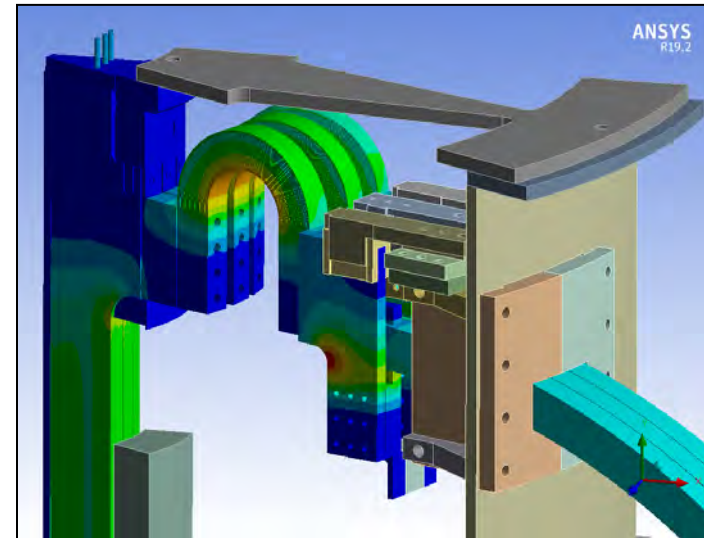
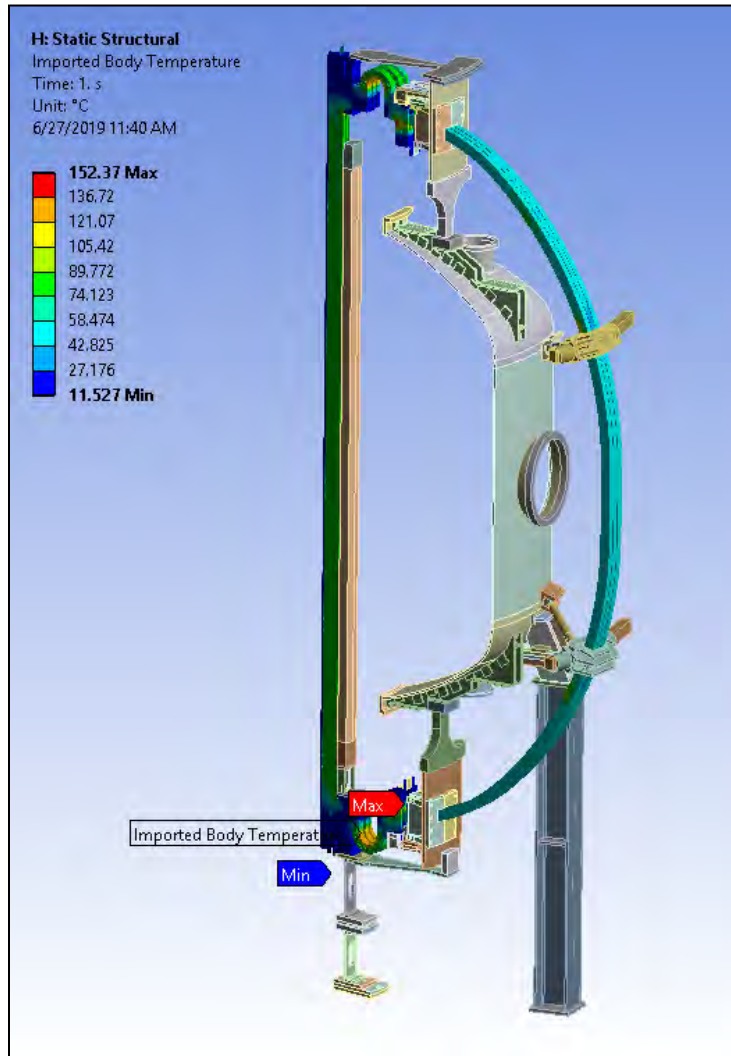

Static Structural Cyclic Sym. Model: Imported Loads Body Force Density

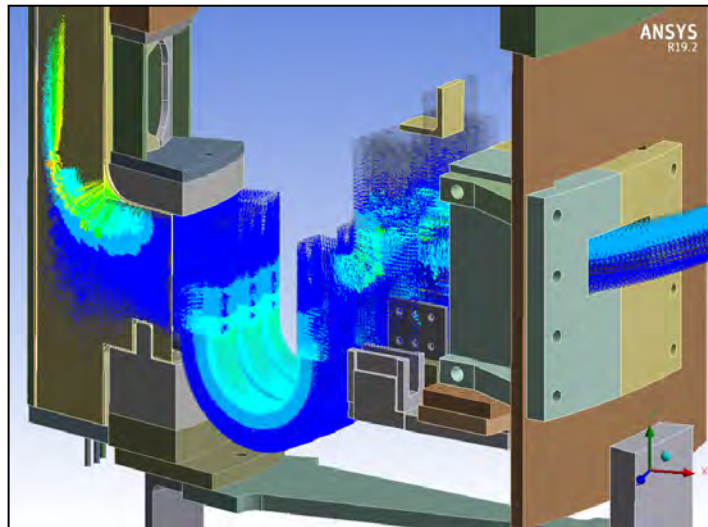
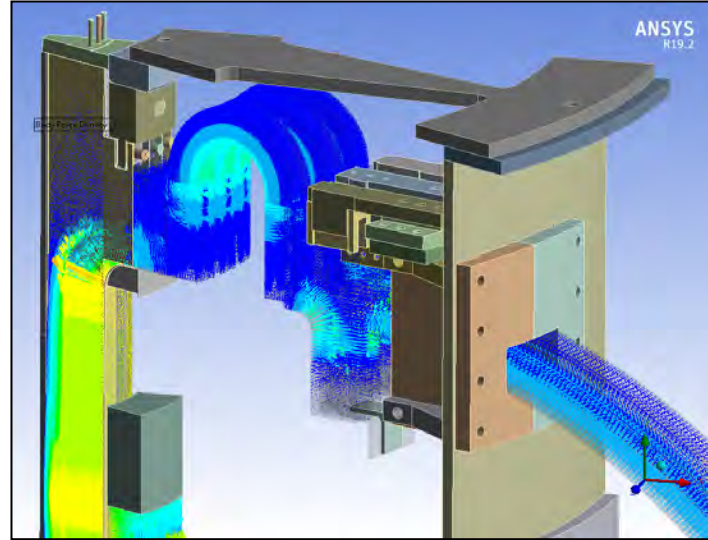
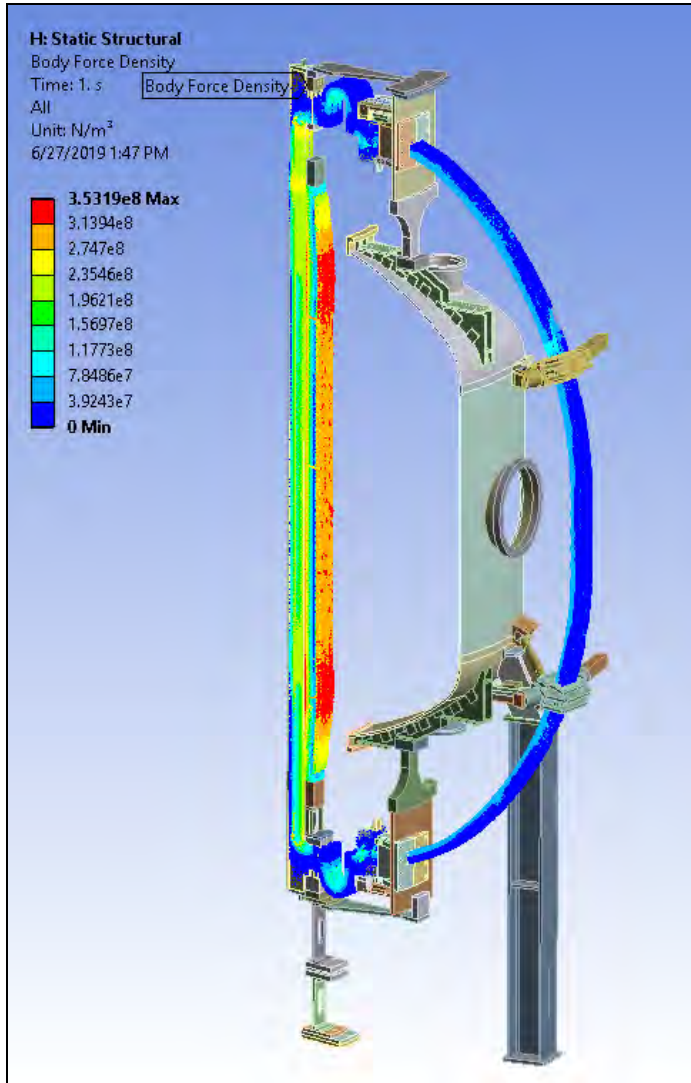

Static Structural Cyclic Sym. Model: Y-Axis Deformation

SC#1: Inlet Water Temperature = 12 C; Water Flow Rate = 2.5 GPM/ Leg

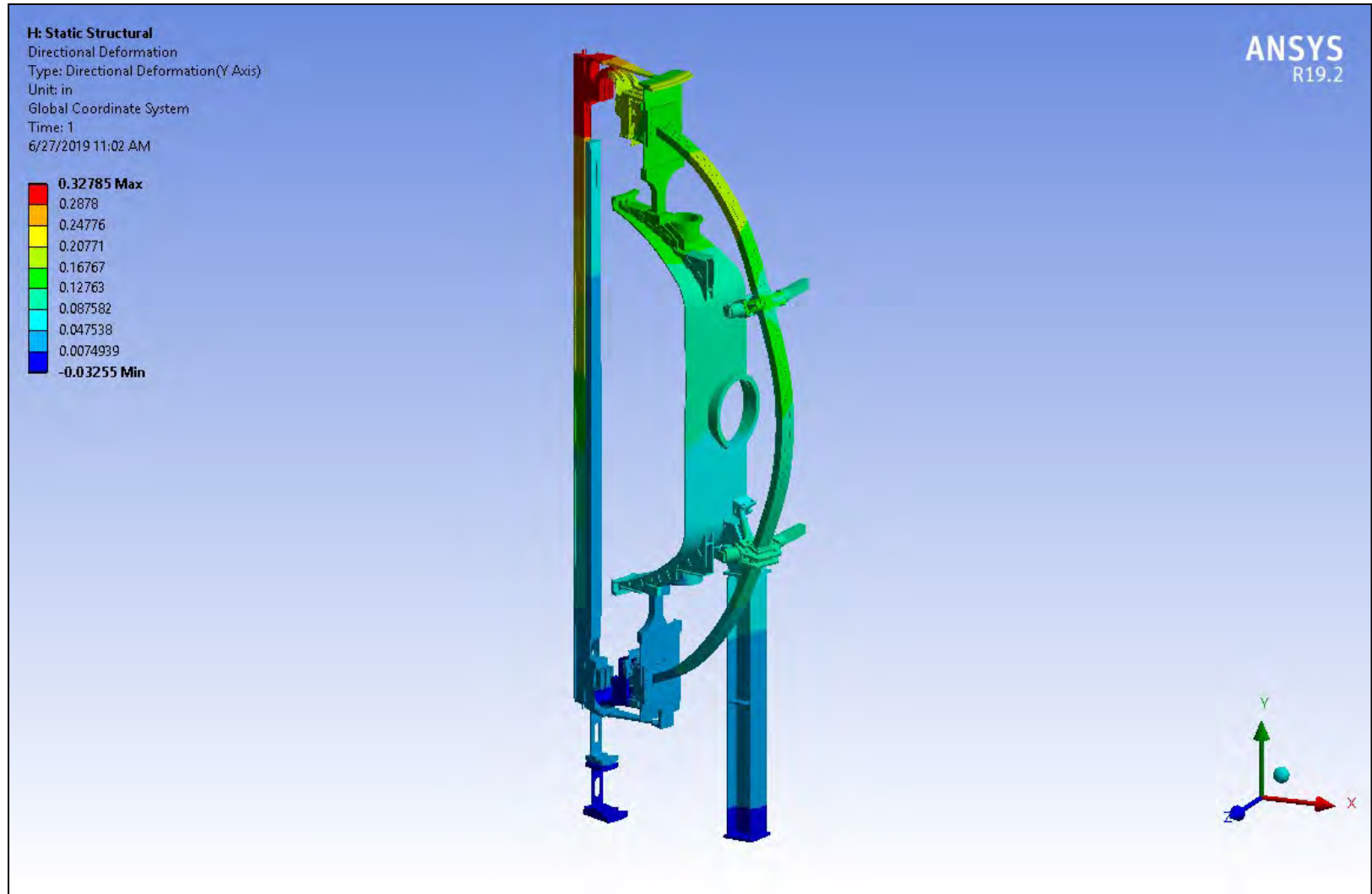

Static Structural Cyclic Sym. Results: Y-Axis Deformation

SC#1: Inlet Water Temperature = 12 C; Water Flow Rate = 2.5 GPM/ Leg

360° Visual Expansion

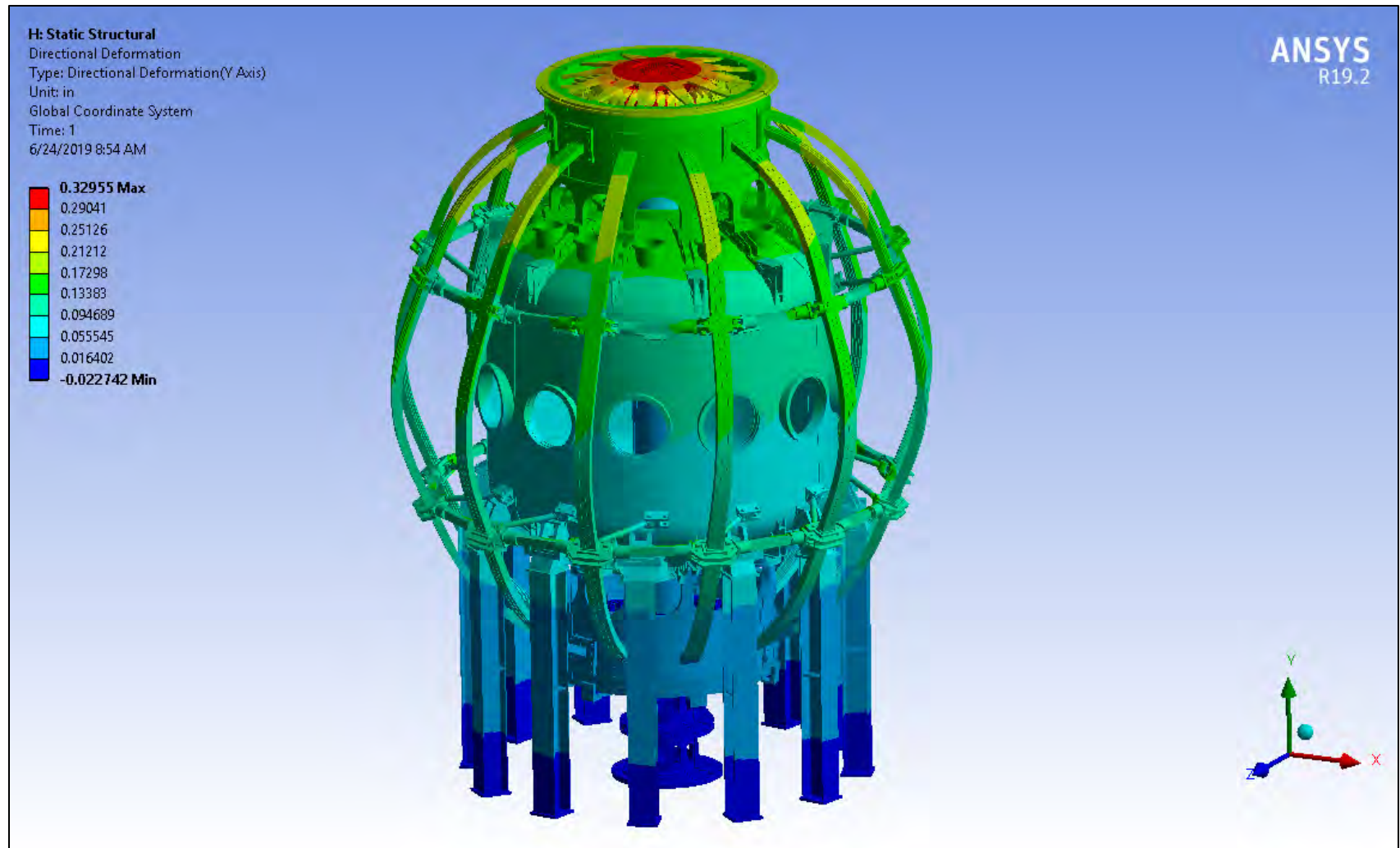

Static Structural Cyclic Sym. Results: Insulation Normal Stress

SC#1: Inlet Water Temperature = 12 C; Water Flow Rate = 2.5 GPM/ Leg

Stress Free Reference Temperature = 22 C

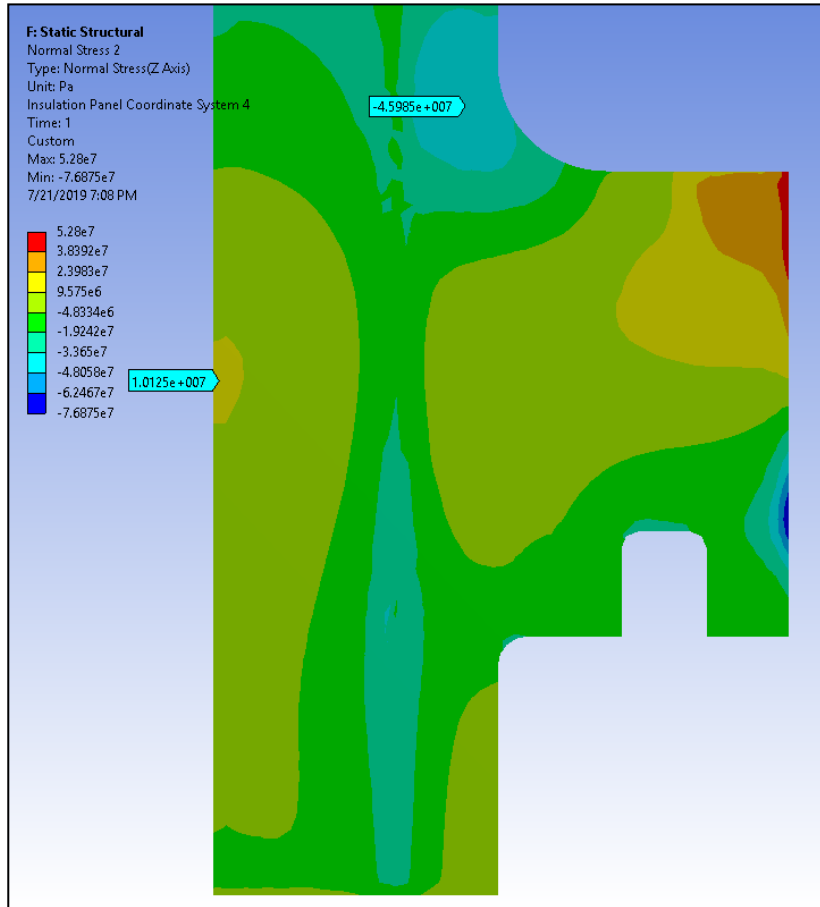

Lower Flag

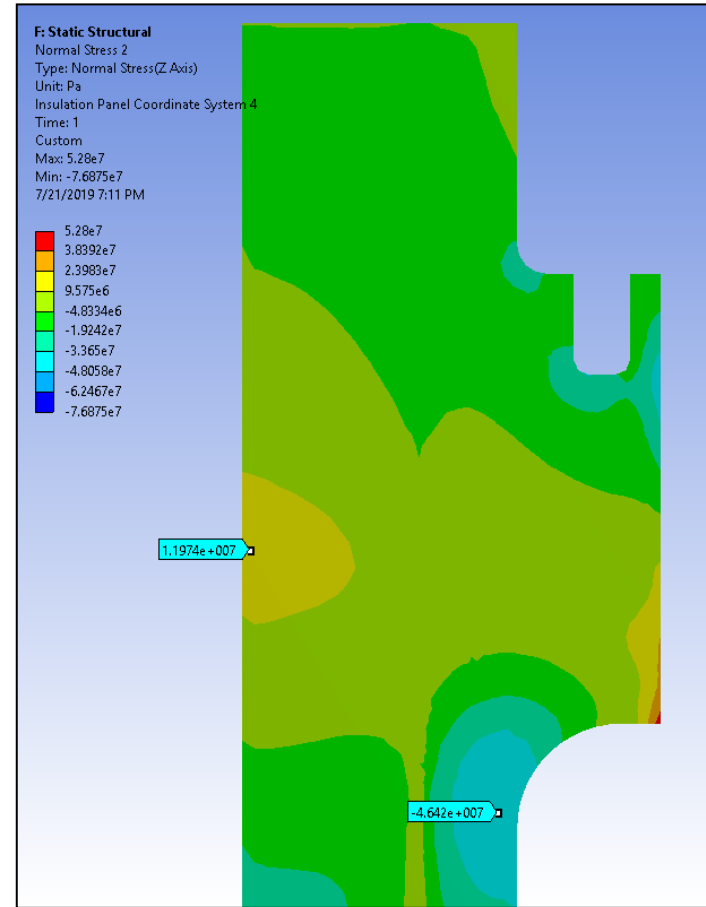

Upper Flag

Static Structural Upper Flag Area Submodel: Solid Model

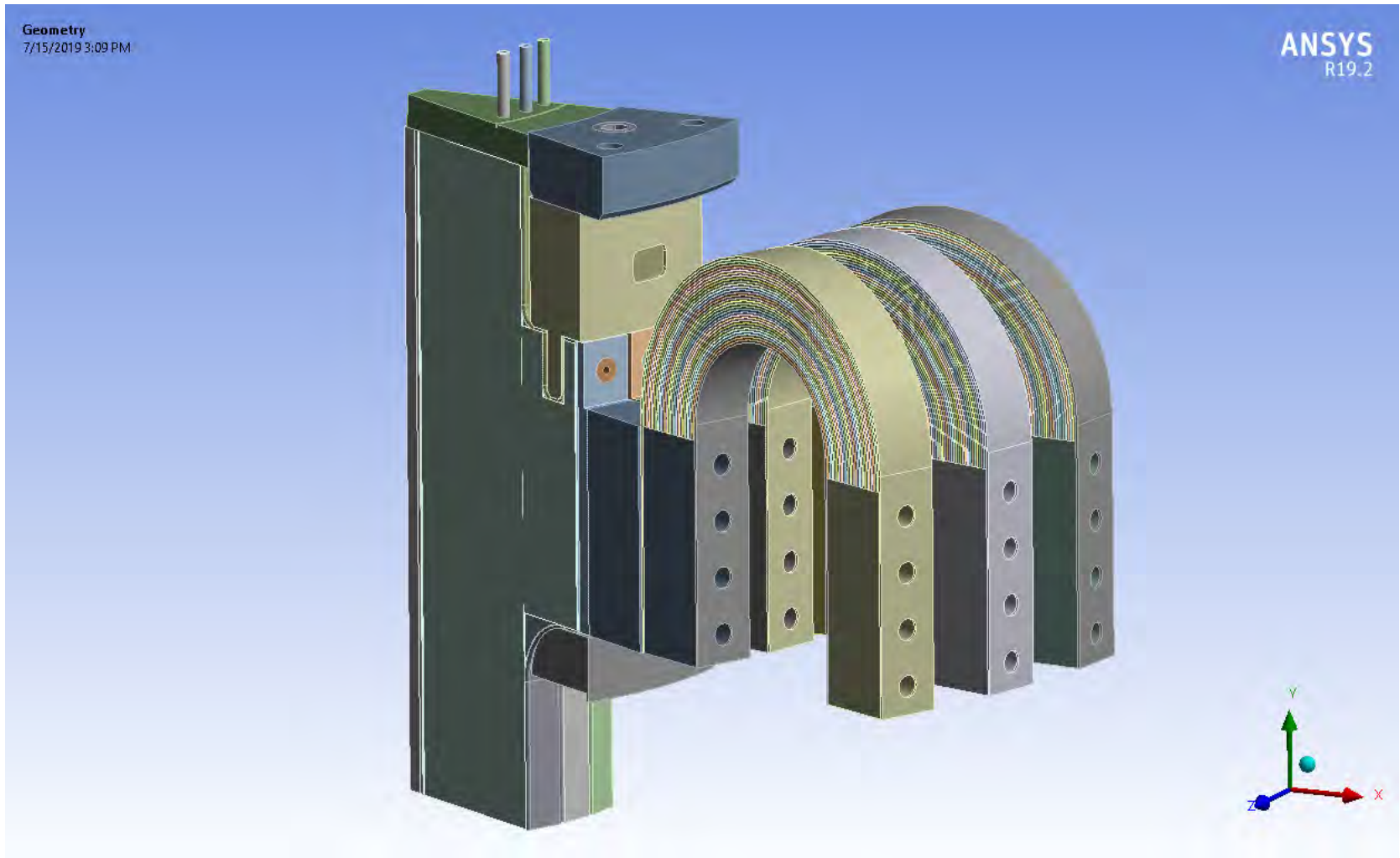

Static Structural Upper Flag Area Sub Model: Mesh

Nodes = 5E06; # Elements = 5E06

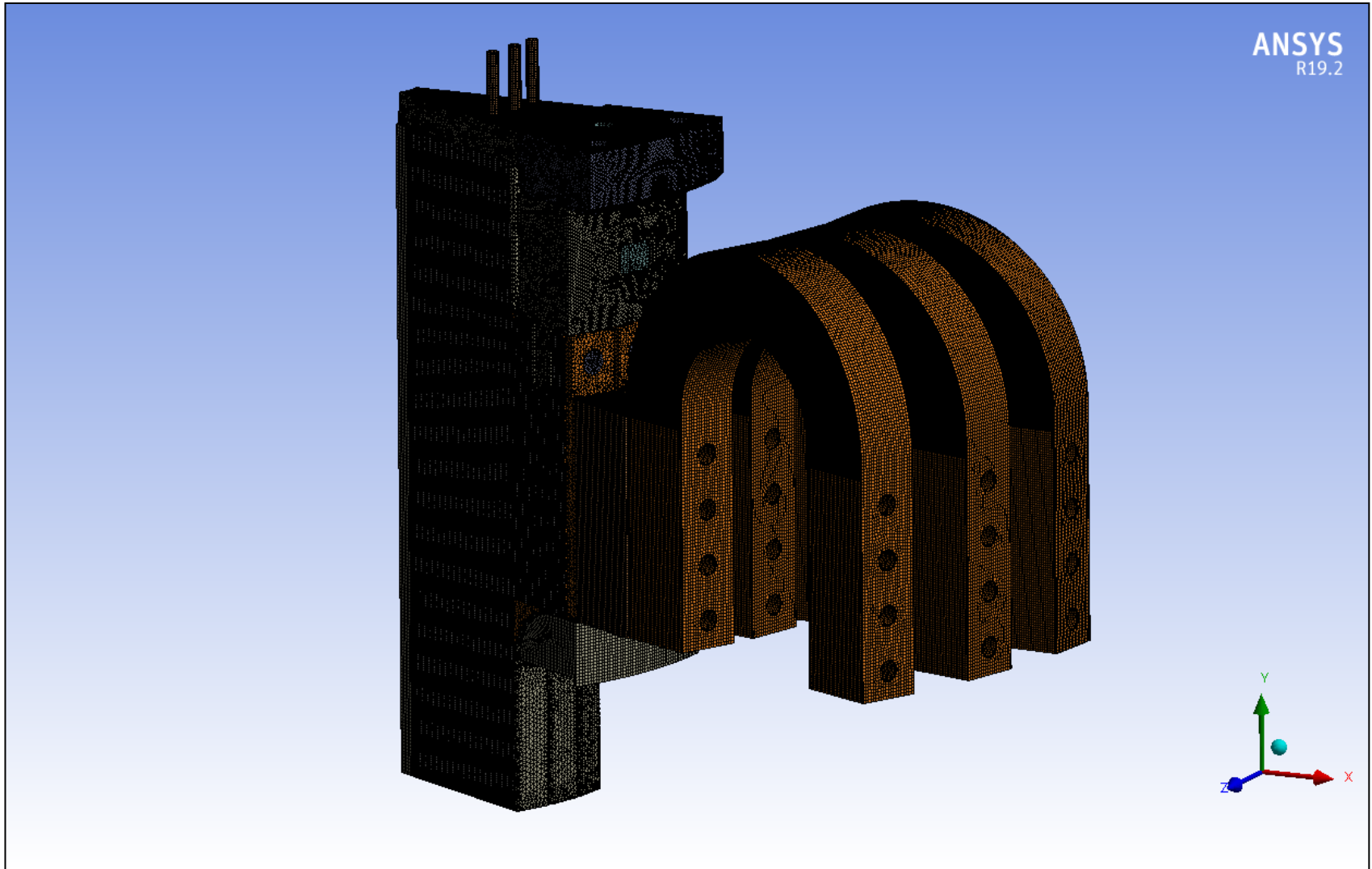

Static Structural Upper Flag Area Submodel: Loads Boundary Conditions Gravity; Applied Forces

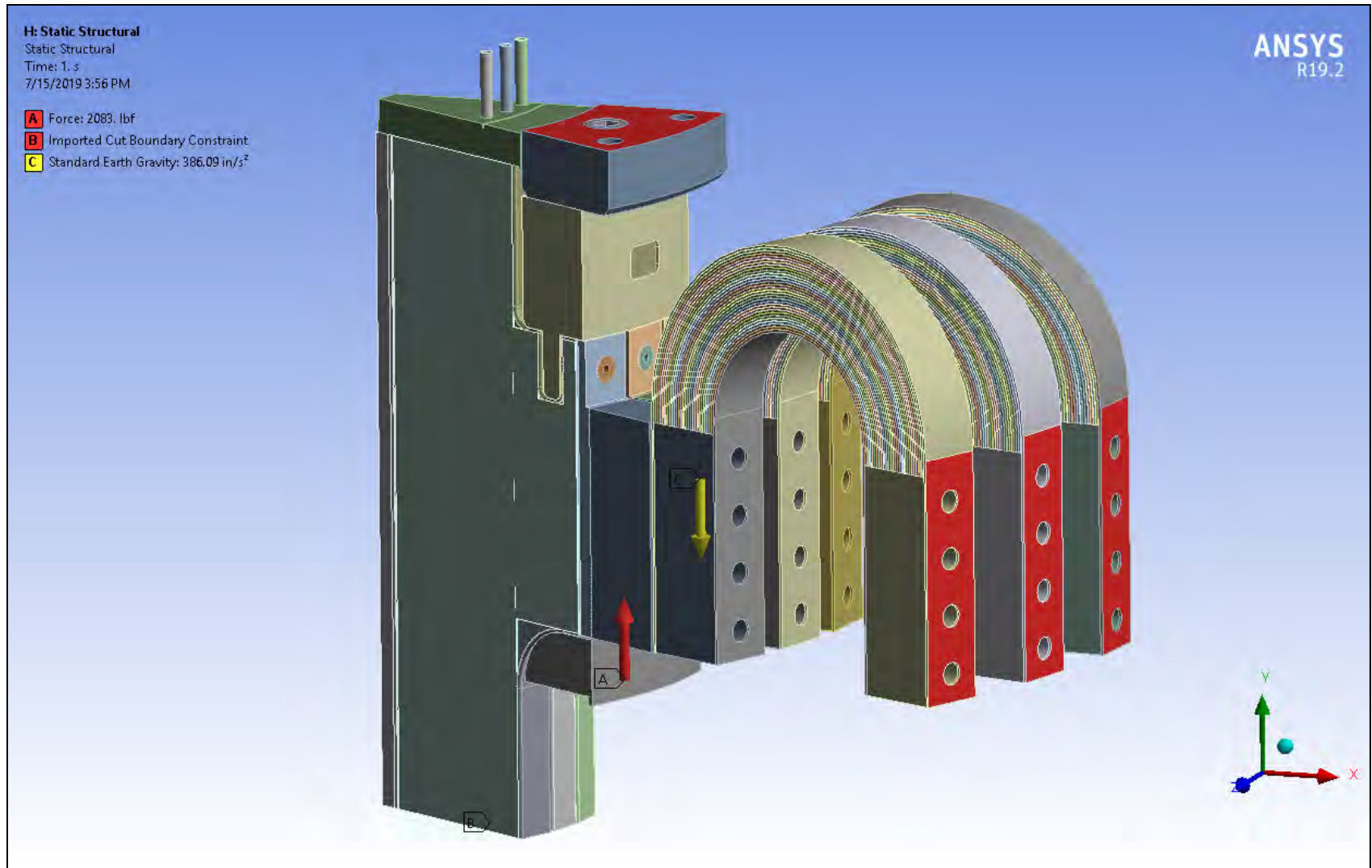

Static Structural Upper Flag Area Submodel: Loads + Boundary Conditions

Body Force Density

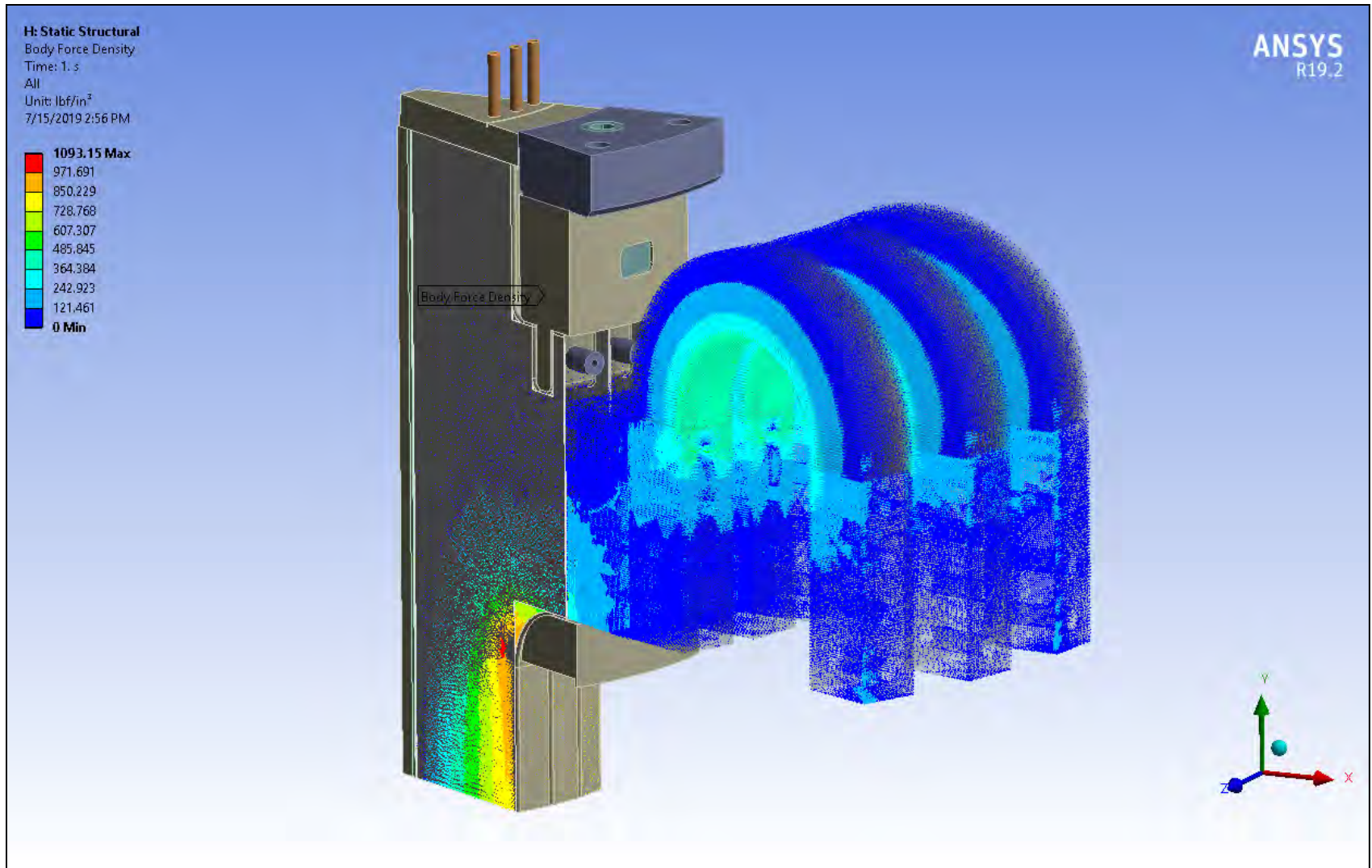

Static Structural Upper Flag Area Submodel: Loads + Boundary Conditions

Body Temperature

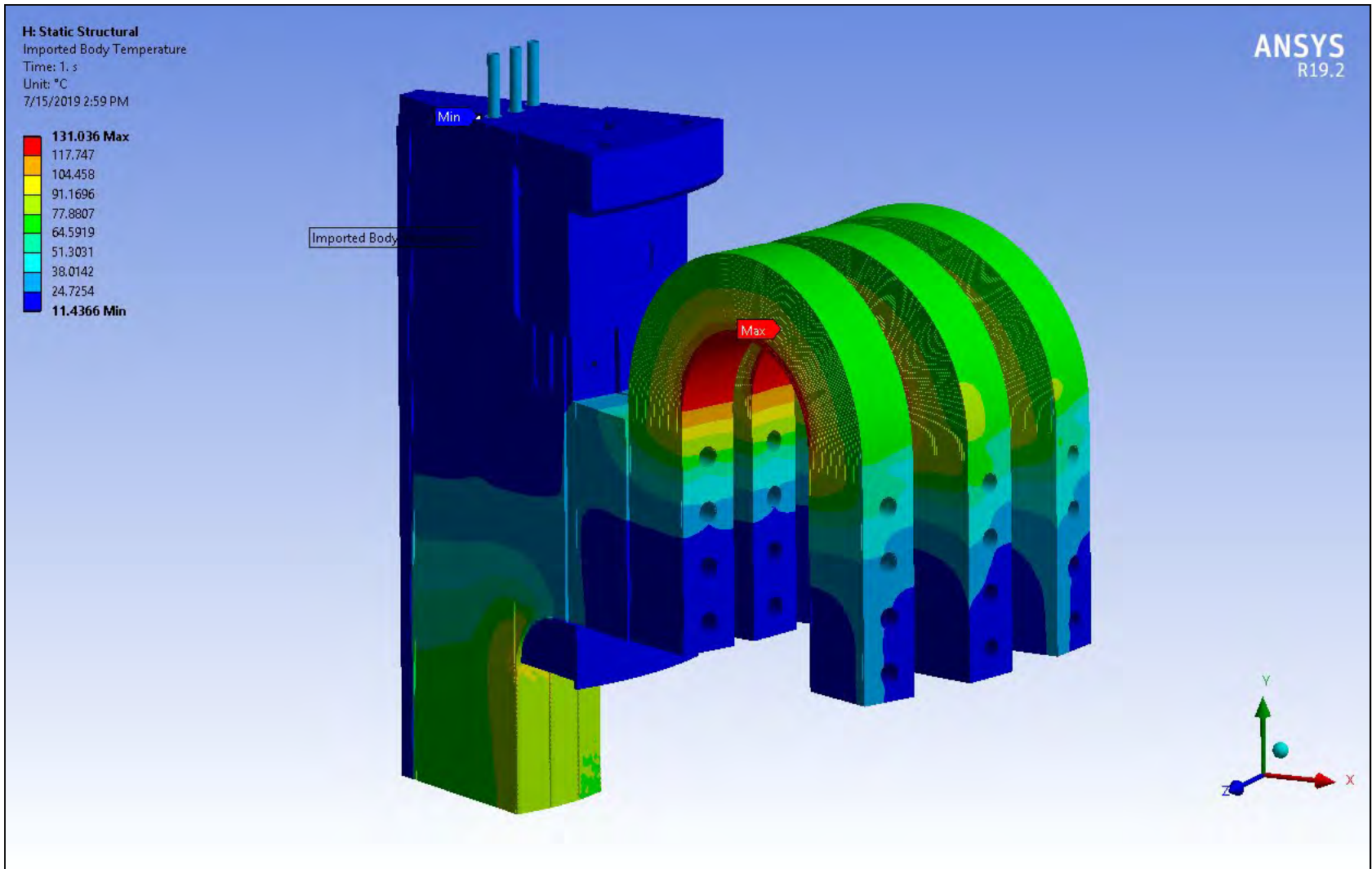

Static Structural Upper Flag Area Submodel: Loads + Boundary Conditions

Cut Plane Displacements

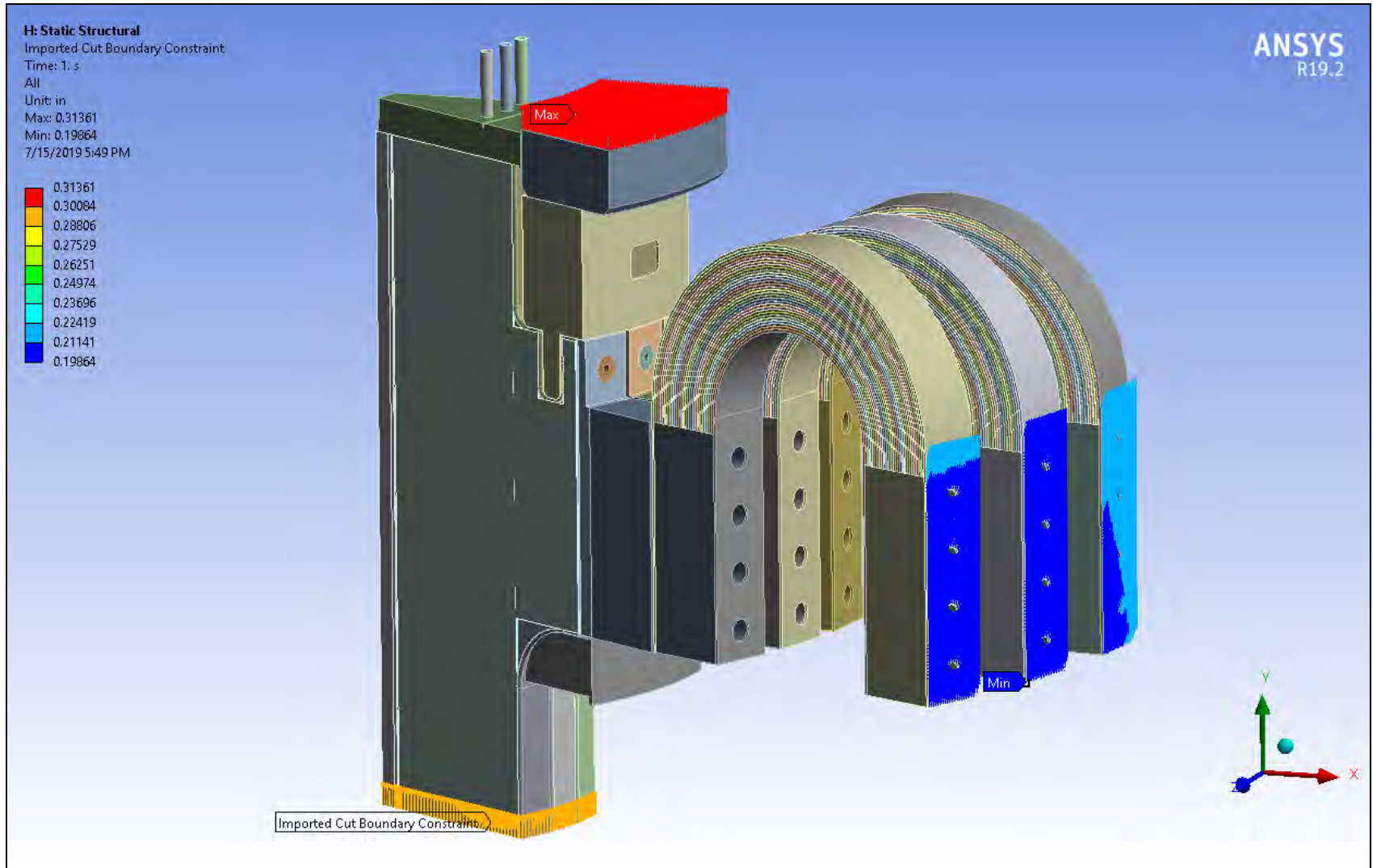

Static Structural Upper Flag Area Results: Insulation Normal Stress

SC#1: Inlet Water Temperature = 12 C; Water Flow Rate = 2.5 GPM/ Leg

Stress Free Reference Temperature = 22 C

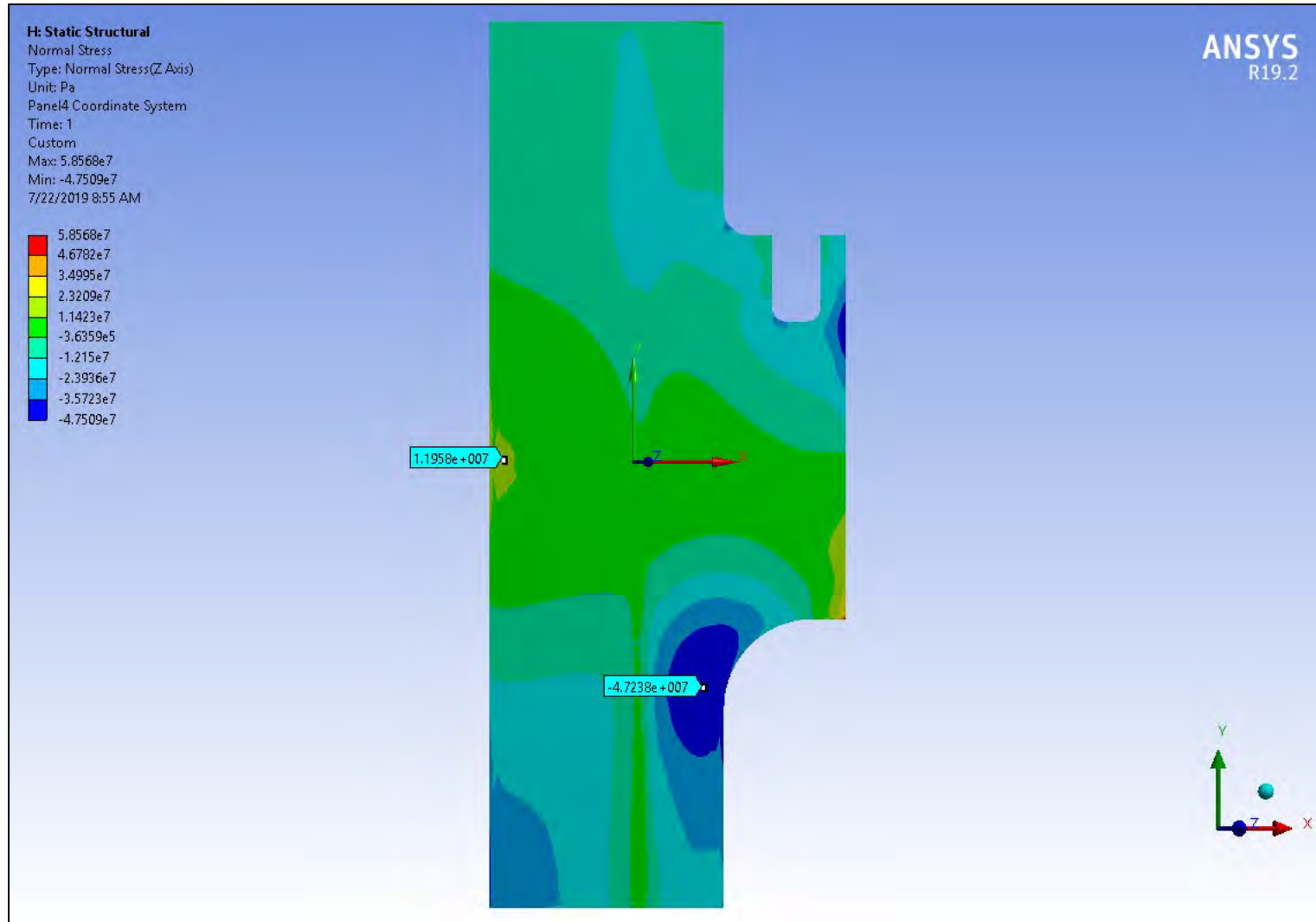

Static Structural Lower Flag Area Submodel: Solid Model

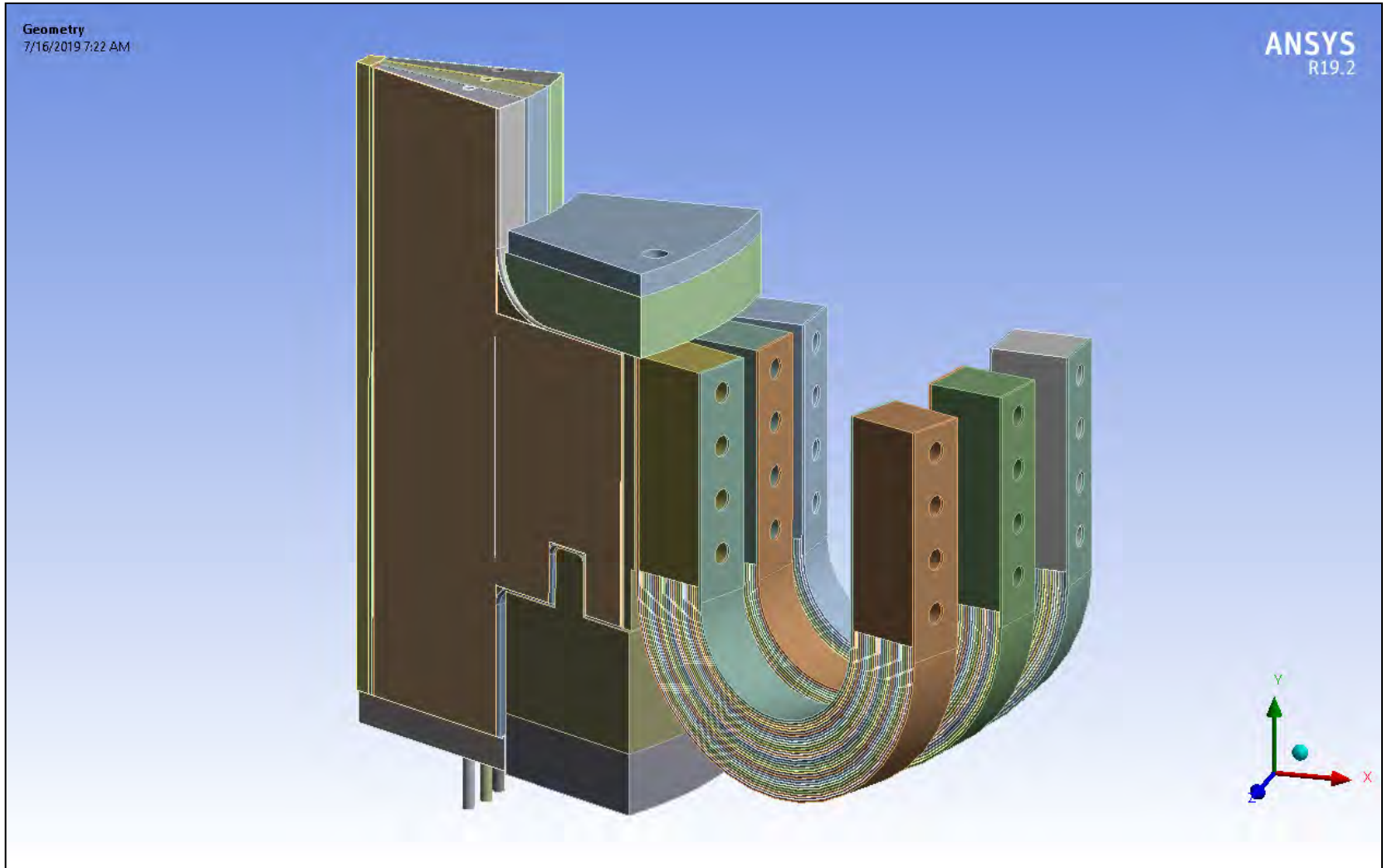

Static Structural Upper Flag Area Sub Model: Mesh

Nodes = 3.31E06; # Elements = 4.95E06

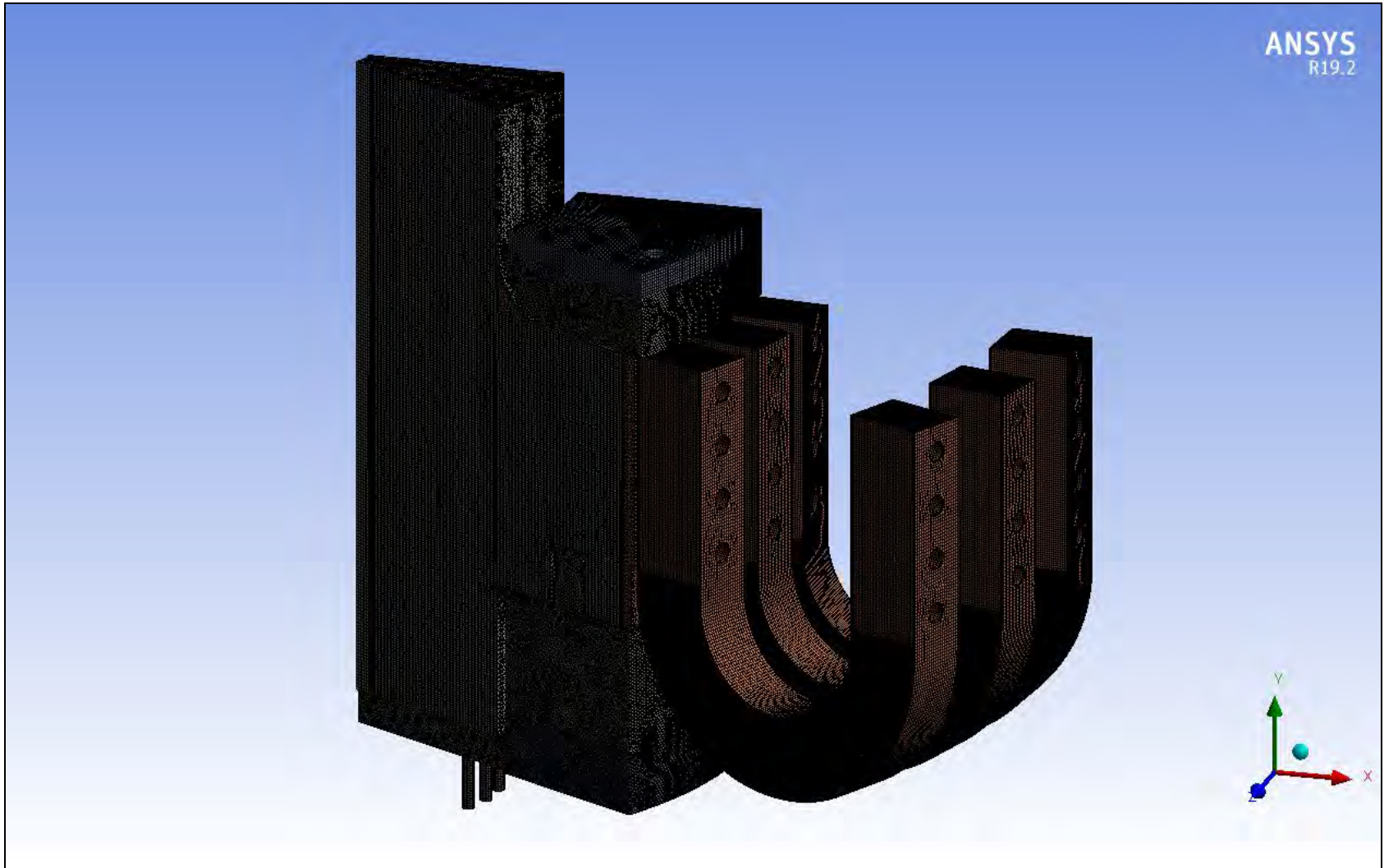

Static Structural Upper Flag Area Submodel: Loads Boundary Conditions Gravity; Applied Forces

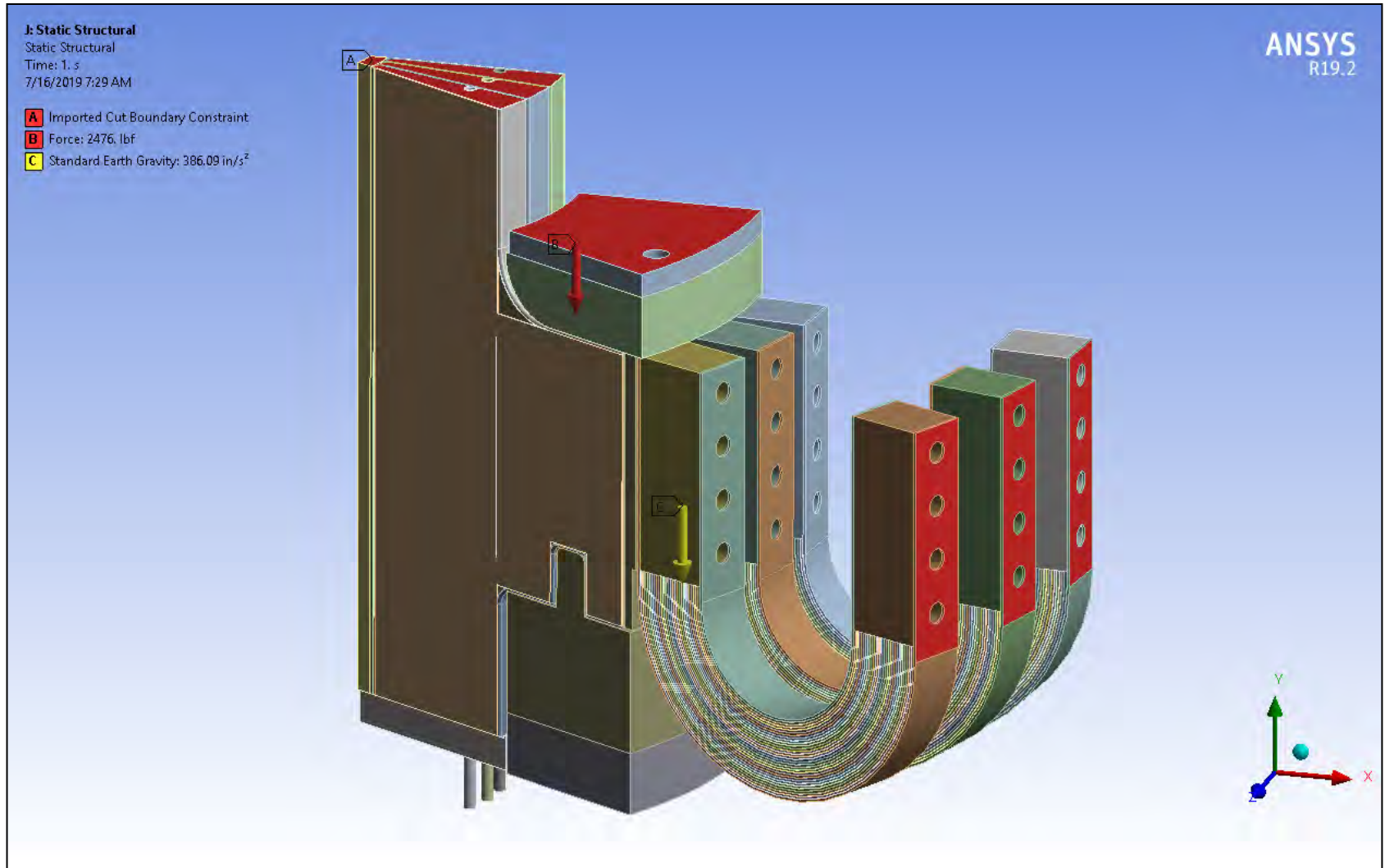

Static Structural Lower Flag Area Submodel: Loads + Boundary Conditions

Body Force Density

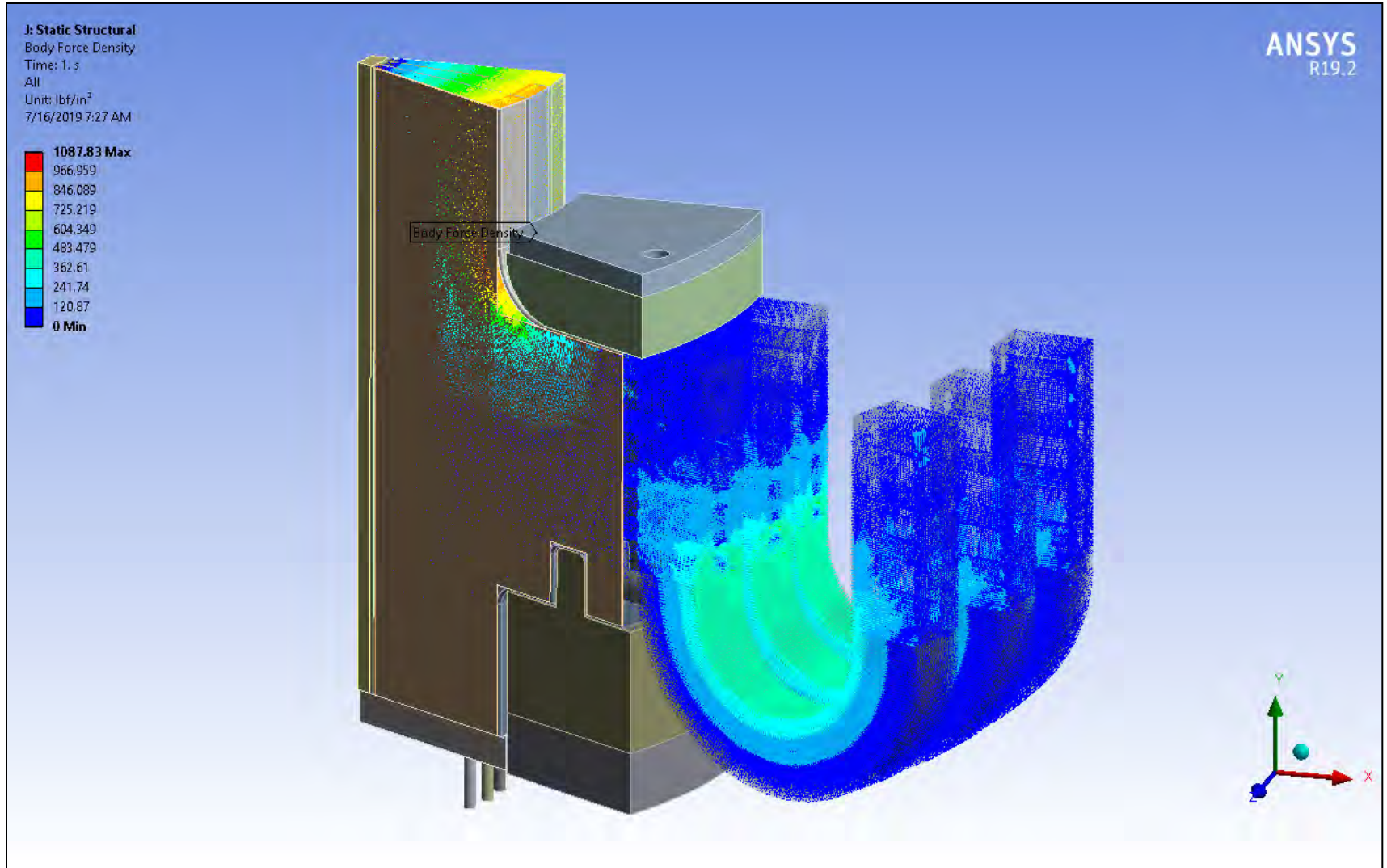

Static Structural Upper Flag Area Submodel: Loads + Boundary Conditions

Body Temperature

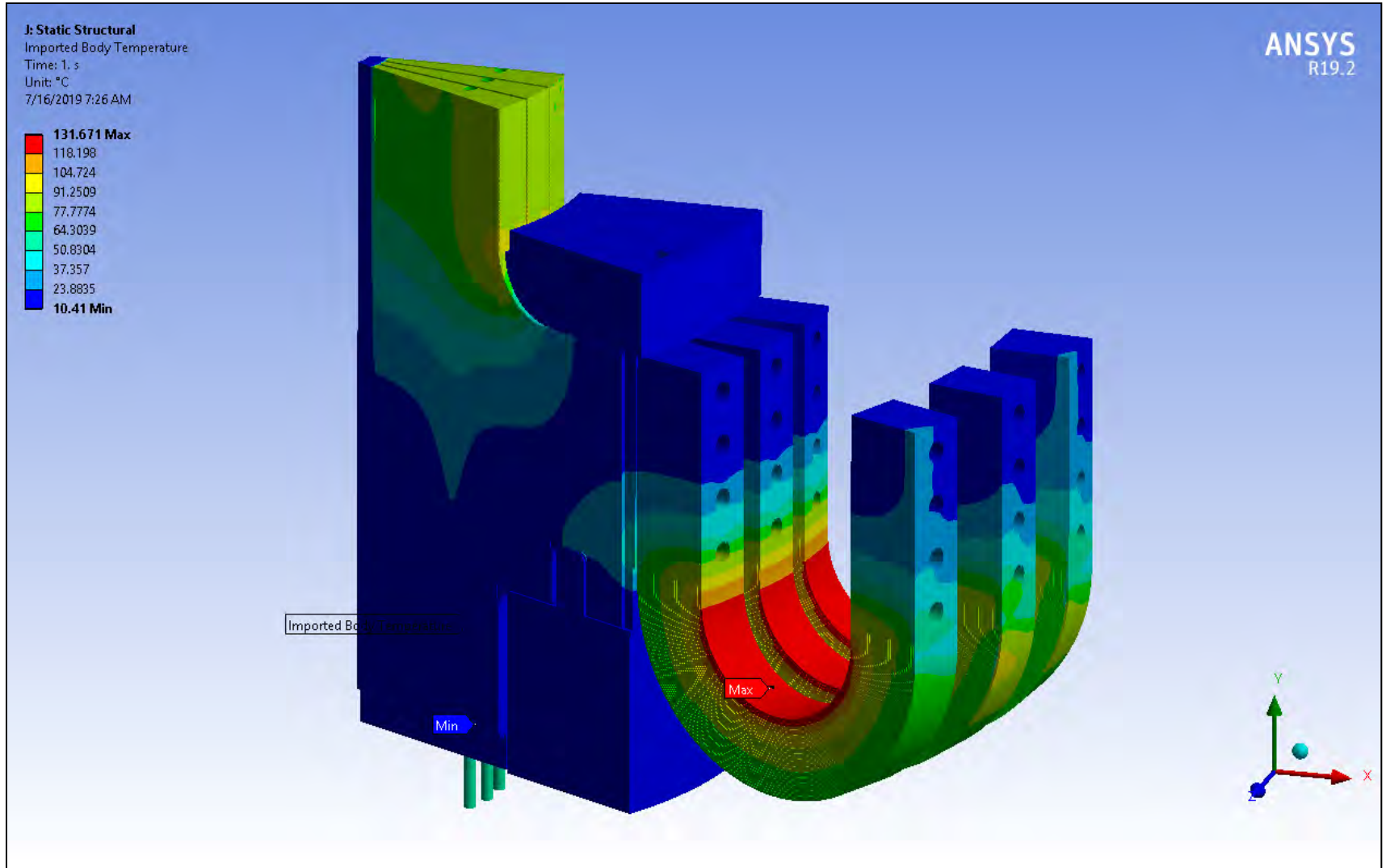

Static Structural Upper Flag Area Submodel: Loads + Boundary Conditions

Cut Plane Displacements

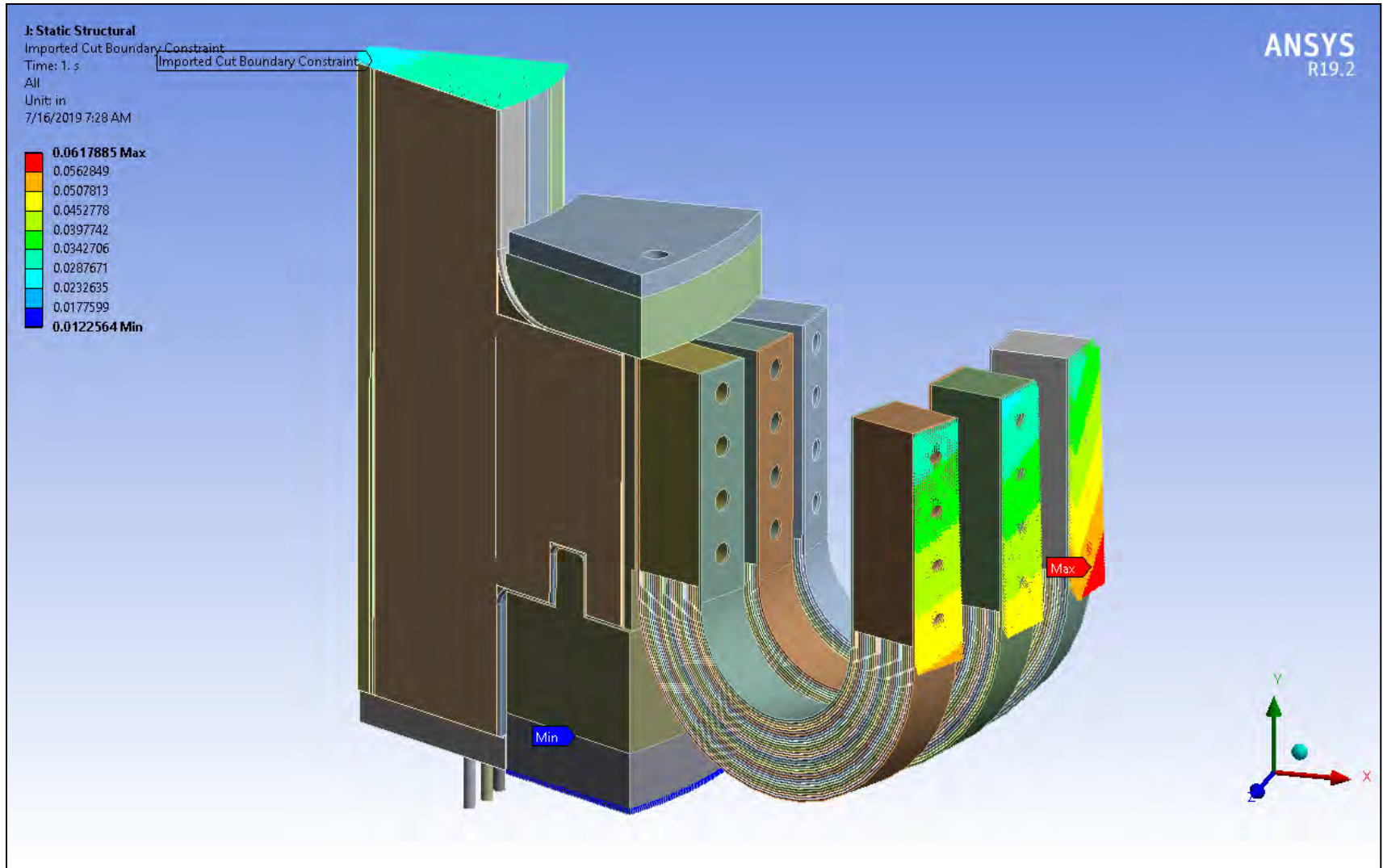

Static Structural Lower Flag Area Results: Insulation Normal Stress

SC#1: Inlet Water Temperature = 12 C; Water Flow Rate = 2.5 GPM/ Leg
Stress Free Reference Temperature = 22 C

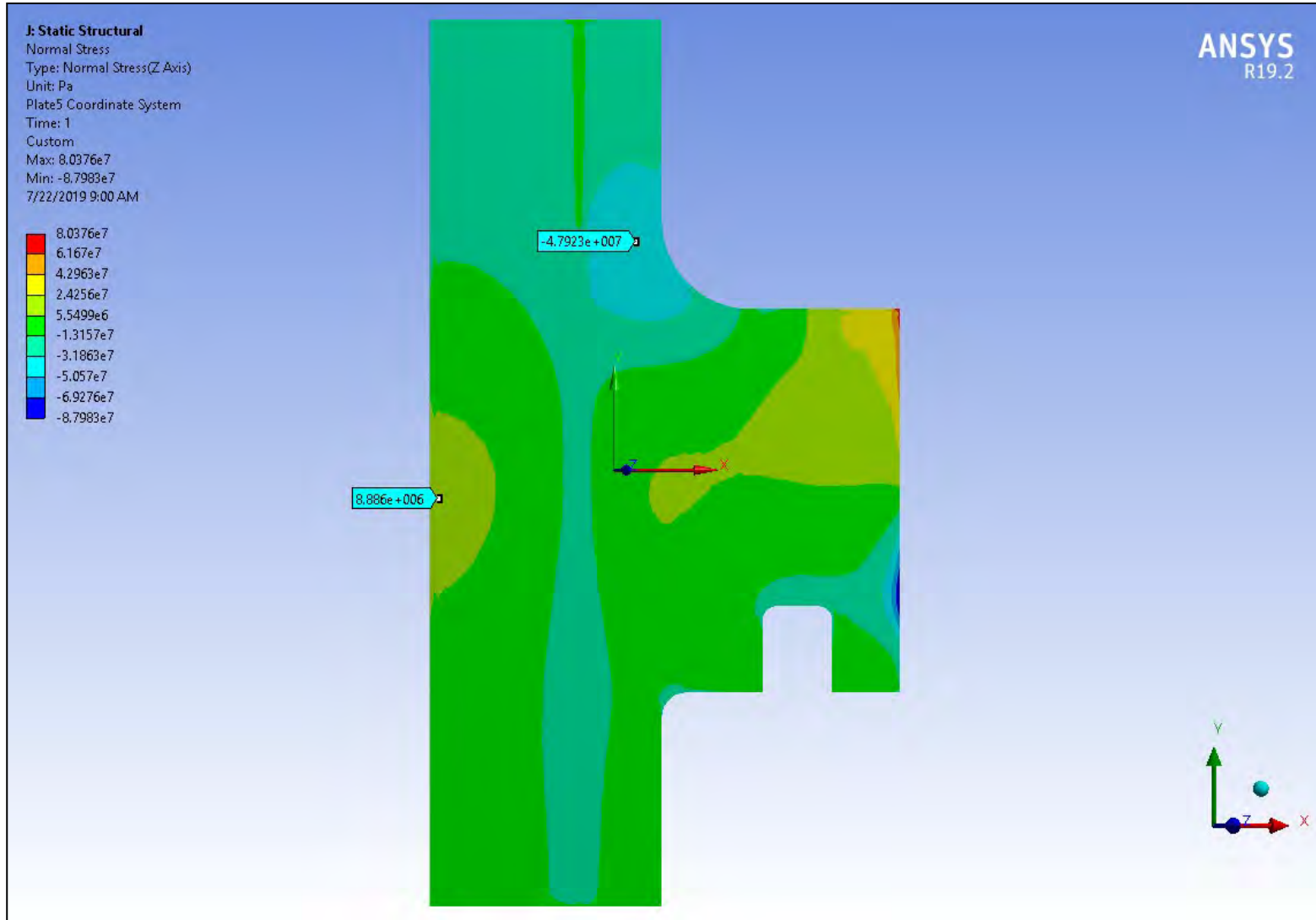

Static Structural Cyclic Sym. Model: Bundle Insulation Normal Stress

Insulation Stress Free Reference Temperature Study:

Table I - Insulation Normal Stress vs. Stress-Free Reference Temperature

Test #	Assigned Stress-Free Reference Temperature (C)		Avg. Insulation Normal Stress (MPa)		Conductor Vertical Displacement (in)		Comments
	Conductor	Insulation	Bundle Temperature (C)		Bundle Temperature (C)		
			22	100	22	100	
1	22	22	0	-1.31E+04	0	0.161	Globally non-conservative
2	100	100	1.31E+04	0	-0.161	0	Most accurate
3	22	100	-1.83E+05	-1.96E+05	0	0.146	Globally non-conservative

Notes:

1. Test #1 determines the stress at operating temp. using PPPL historical stress-free reference temperature.
2. Test #2 determines residual stress at room temperature after cooldown from 100 C cure temperature.
3. Test #3 determines the stress at operating temperature using different Cu/Insul. stress-free temperatures.

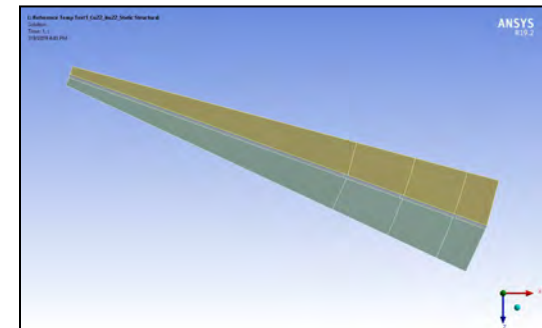
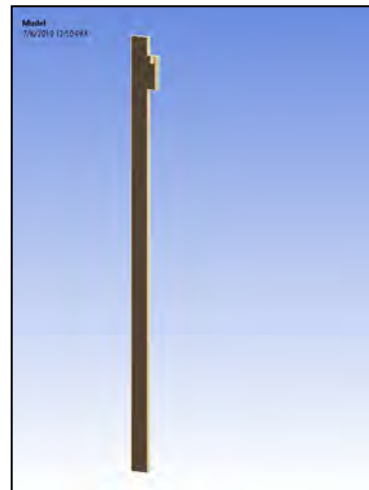
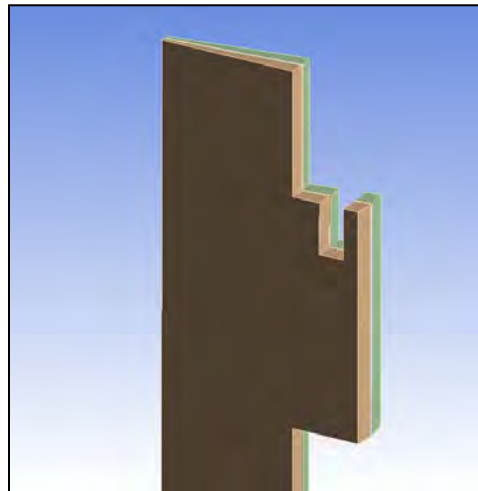

Static Structural Cyclic Sym. Model: Bundle Insulation Normal Stress

Insulation Stress Free Reference Temperature Study:

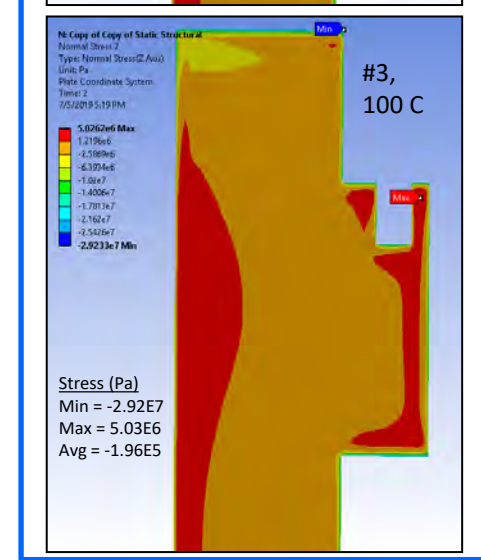
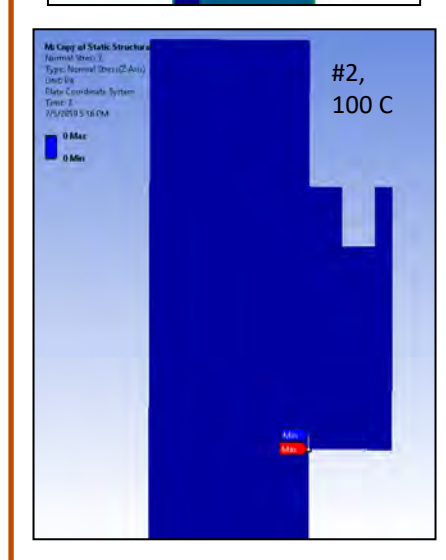
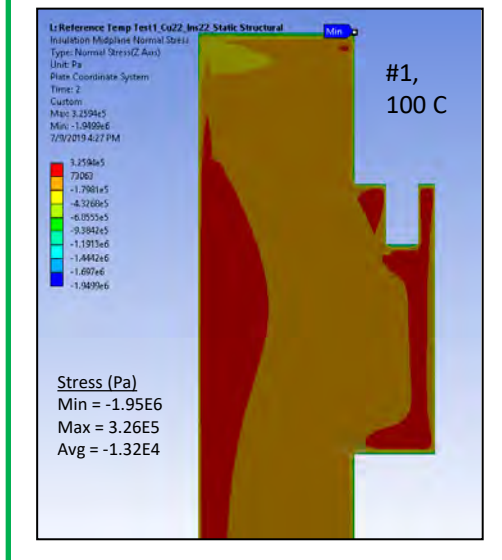
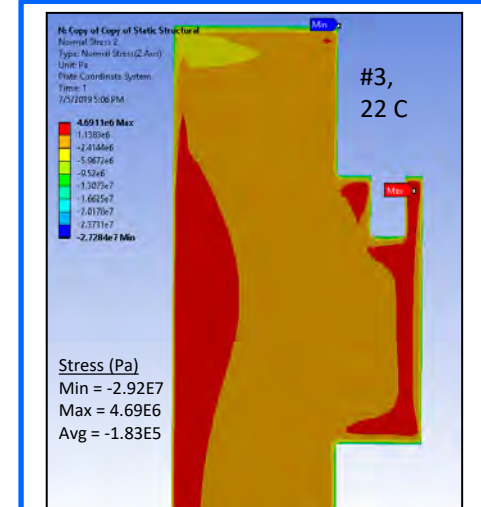
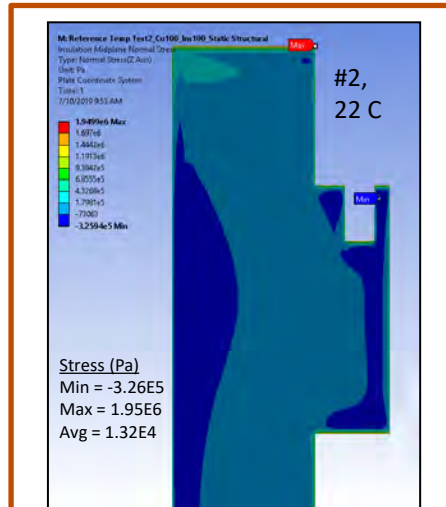
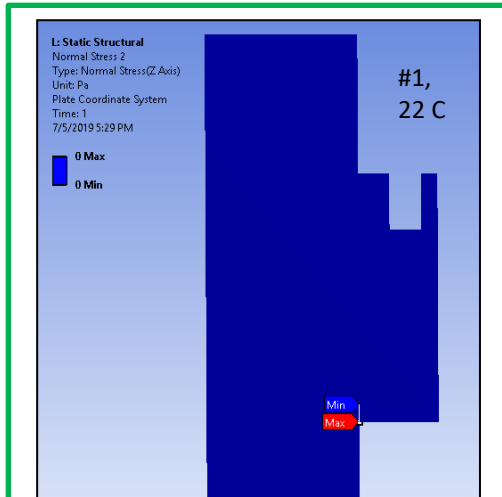

Static Structural Cyclic Sym. Model: Bundle Insulation Normal Stress

Insulation Stress Free Reference Temperature Study:
Test #1, 100 C, With Insulation (Not Shown)

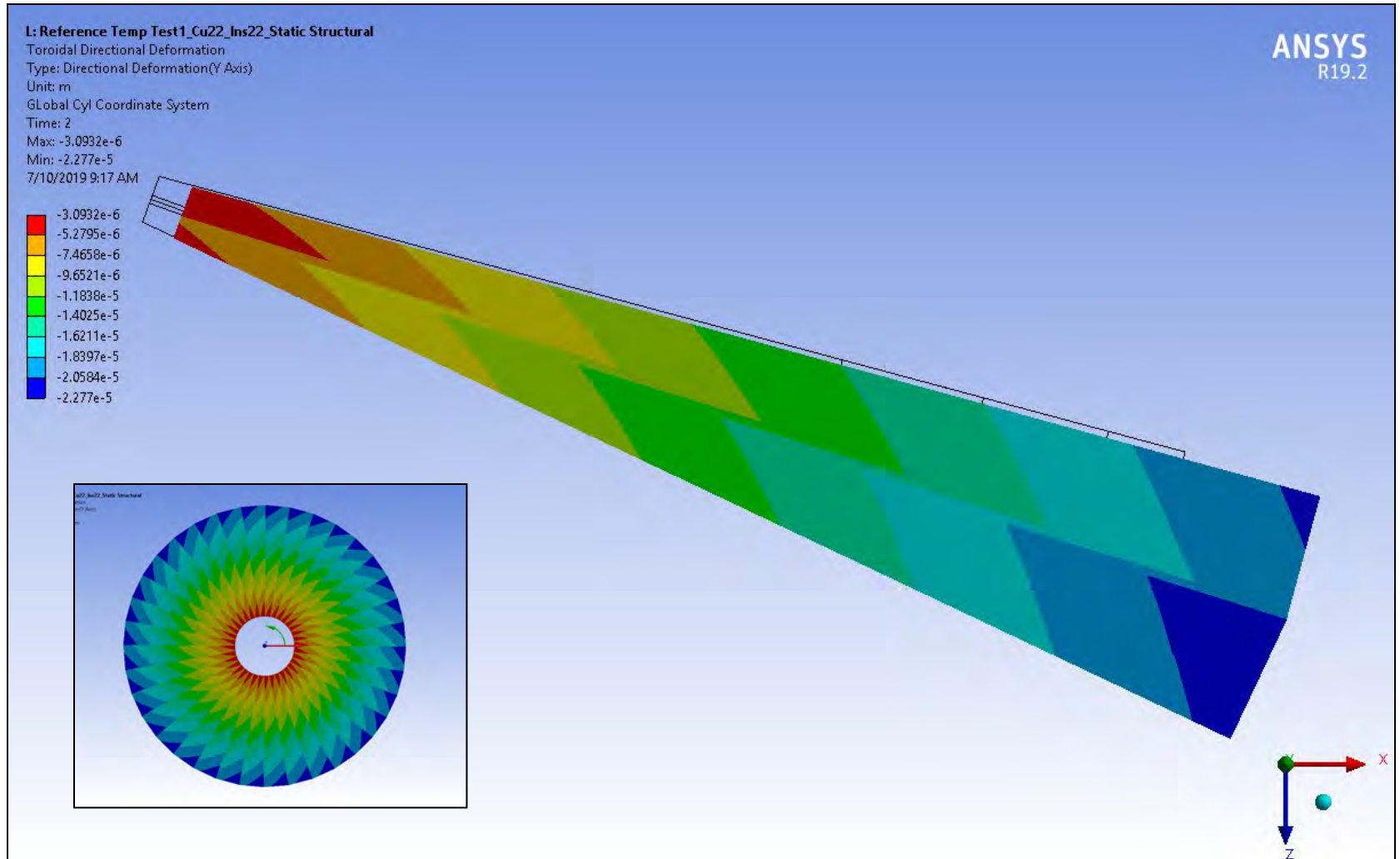

Static Structural Cyclic Sym. Model: Bundle Insulation Normal Stress

Insulation Stress Free Reference Temperature Study: Conclusions and Recommendations

1. The results show that assuming a room temperature stress-free reference temperature is non-conservative globally (compressive), but may be too conservative locally in the high normal tension stress area of the flags.
2. Recommend running a separate analysis of an unconstrained/ free standing TF bundle to determine the room temperature residual stress after cooldown from a 100 C curing temperature (stress-free reference temperature for both conductor and insulation = 100 C), then applying that residual stress as an initial condition. Done correctly, this should result in nearly zero residual stress at operating temperature, the correct thermal growth of the bundle, and may lower the local peak normal stresses in the insulation. Note: the same effect can be achieved by adding a load step to the existing static structural model.
3. Kevin Freudenberg's advice for including the residual stress effects in the TF bundle analysis is:
 1. Since the residual stress at operating temperature is so low, and would likely reduce the normal tension stress, ignore it at operating temperature; but
 2. Determine the residual stress at the initial temperature of 12 C and use this in the cyclic stress fatigue calculations.

Static Structural TF Inner Bundle Residual Stress Results: Z-Deformation

Environmental Temperature 12 C
Stress-Free Reference Temperature = 100 C C

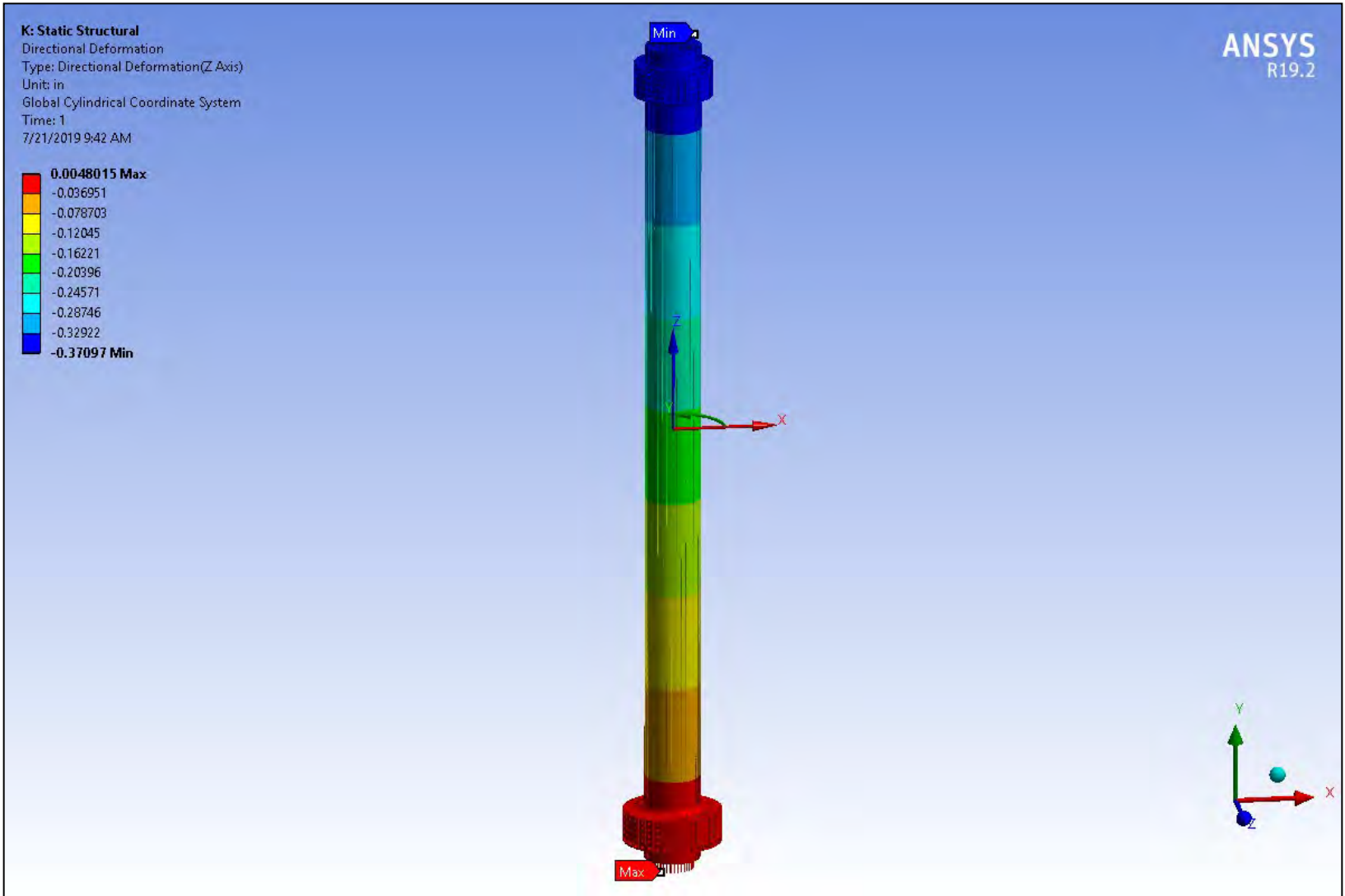

Static Structural Residual Stress Results: Insulation Normal Stress

Environmental Temperature = 12 C

Stress Free Reference Temperature = 100 C



Lower Flag

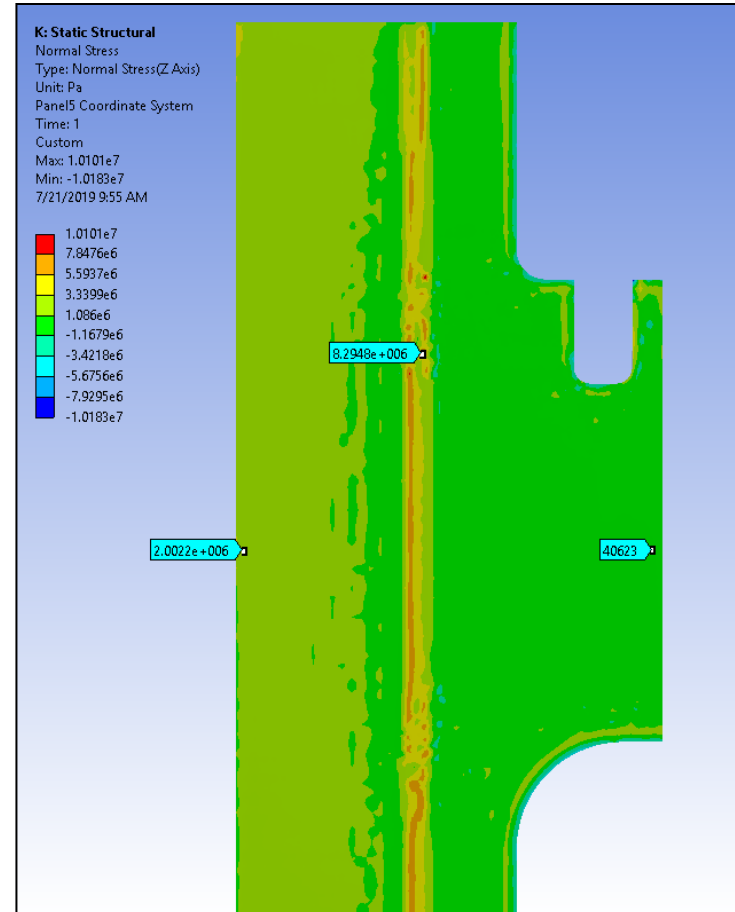

Upper Flag

Static Structural Cyclic Sym. Model: External Load Path

Load Paths and Force: Contact/ Boundary Condition Probe Locations

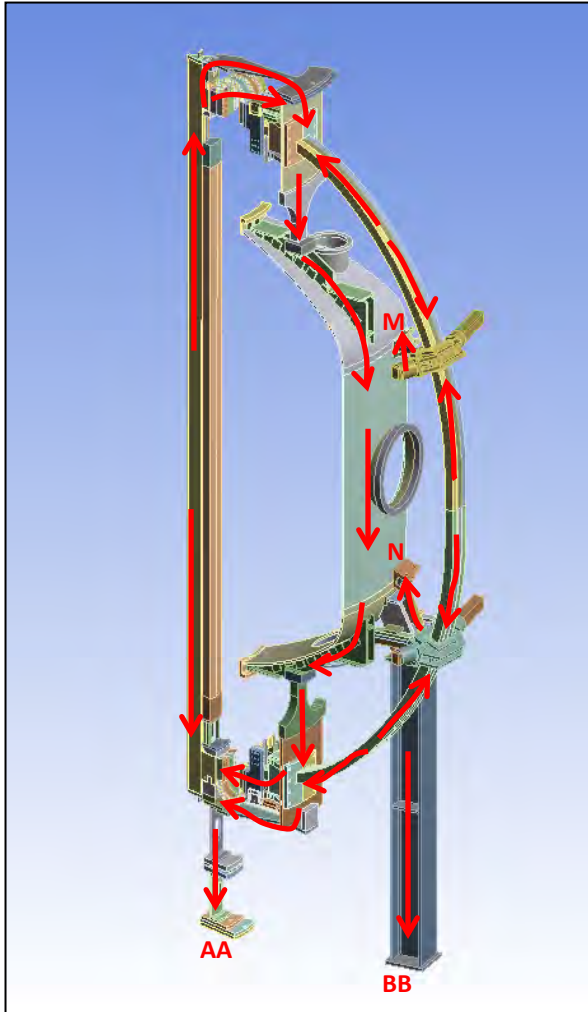

Load Paths

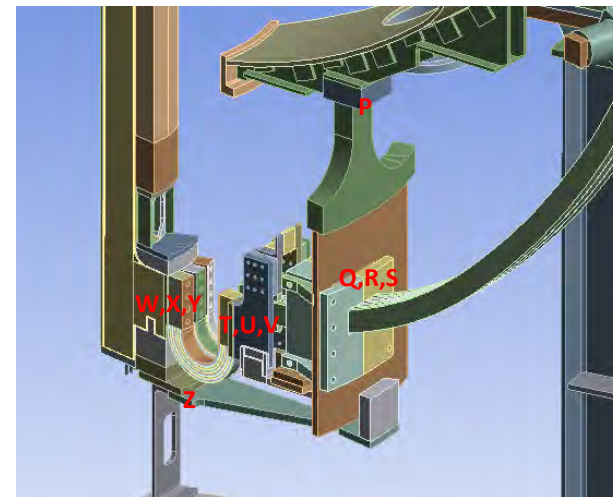
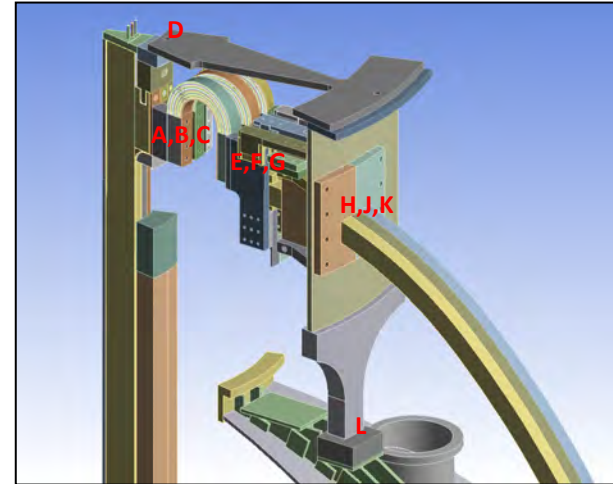

Probe Locations

Static Structural Cyclic Sym. Model: External Load Path

Load Paths and Forces: Contact/ Boundary Condition Probe Forces

Table 1 - Contact Region and Boundary Condition Probe Forces Comparison

Item #	Probe Location	Description	Coordinate System	Baseline			Worst-Case Delamination			Max % Change
				F _r (lbf)	F _θ (lbf)	F _z (lbf)	F _r (lbf)	F _θ (lbf)	F _z (lbf)	
1	AA	Pedestal Base-to Floor	Global Cylindrical	-3.36E+06	457.1	27598	-3.36E+06	6256.3	28029	Cyclic
2	BB	Vessel Support Leg-to-Floor		-2.02E+05	1374.1	63517	-2.02E+05	1671.2	66226	Cyclic
3	A	Upper Flag A-to-Flex Strap		46343	-10139	-55023	46325	-10104	-55035	0.35%
4	B	Upper Flag B-to-Flex Strap		46248	-9142.5	-54669	46237	-9104.9	-54669	0.41%
5	C	Upper Flag C-to-Flex Strap		46527	-9700	-55151	46524	-9664.5	-55147	0.37%
6	D	Upper Lid-to-TF Bundle		1.06E+05	73842	-10593	1.06E+05	64231	-10659	Cyclic
7	E	Upper Flex A-to-Lead Extension E		25321	17250	45356	25280	17269	45353	0.16%
8	F	Upper Flex B-to-Lead Extension F		17102	18016	43747	17091	18040	43764	0.13%
9	G	Upper Flex C-to-Lead Extension G		24122	17850	45074	24116	17871	45084	0.12%
10	H	Upper Aluminum Block-to-TF Outer Leg H		2.49E+05	5.72E+05	1.23E+05	2.47E+05	5.71E+05	1.26E+05	Pinball
11	J1	Upper Aluminum Block-to-TF Outer Leg J1		2.37E+05	2.01E+05	1.30E+05	2.26E+05	2.13E+05	1.29E+05	Pinball
12	J2	Upper Aluminum Block-to-TF Outer Leg J2		-1.46E+05	10006	-2.51E+05	-1.46E+05	5925.4	-3.15E+05	Pinball
13	K	Upper Aluminum Block-to-TF Outer Leg K		1.77E+05	-3.56E+05	1.67E+05	1.74E+05	-3.55E+05	1.64E+05	Pinball
14	L	Upper Umbrella Leg-to-Vessel		-48873	2.03E+05	2.88E+05	-48643	2.05E+05	2.88E+05	1.09%
15	M	Upper Tie Rod-to-Clevis		-99992	1.54E+05	-58712	-1.02E+05	1.56E+05	-60334	2.76%
16	N	Lower Tie Rod-to-Clevis		1.31E+05	-1.68E+05	-30427	1.32E+05	-1.70E+05	-30569	1.21%
17	P	Lower Umbrella Leg-to-Vessel		-4.07E+04	-1.84E+05	-2.42E+05	-40799	-1.87E+05	-2.42E+05	1.72%
18	Q	Lower Aluminum Block-to-TF Outer Leg Q		1.05E+05	4.43E+05	-1.29E+05	1.05E+05	4.45E+05	-1.29E+05	Pinball
19	R1	Lower Aluminum Block-to-TF Outer Leg R1		-19163	1.47E+05	-1.40E+05	-26410	1.59E+05	-1.35E+05	Pinball
20	R2	Lower Aluminum Block-to-TF Outer Leg R2		2.19E+06	-23515	-7.63E+05	2.23E+06	-27790	-7.21E+05	Pinball
21	S	Lower Aluminum Block-to-TF Outer Leg S		3.49E+05	-6.13E+05	-1.15E+05	3.46E+05	-6.14E+05	-1.17E+05	Pinball
22	T	Lower Lead Extension T-to-Flex Strap W		25515	-4581	-45664	25443	-4629.9	-45683	1.07%
23	U	Lower Lead Extension U-to-Flex Strap X		17922	-2939.3	-44035	17861	-2989	-44059	1.69%
24	V	Lower Lead Extension V-to Flex Strap Y		24950	-3712.1	-45542	24890	-3795.9	-45568	2.26%
25	W	Lower Flex Strap W-to-Flag W		45814	1881.9	56257	45850	1797.4	56245	4.49%
26	X	Lower Flex Strap X-to-Flag X		46042	2196.9	55795	46007	2109.8	55793	3.69%
27	Y	Lower Flex Strap Y-to-Flag Y		46088	2451.9	56107	45989	2300.4	56117	6.18%
28	Z	Lower Lid-to-Pedestal		27223	-98847	25454	-6867.1	-81955	25527	Cyclic

Notes:

1. Magenta border: upper flag area probes.
2. Red border: lower flag area probes.
3. Probes on cyclic symmetric boundary parts are suspect; will be replaced with probes on new splice plane cuts provided specifically for probe purpose.
4. Probes on contact regions with gaps requiring a large pinball radius are suspect; will be replaced with probes on new splice plane cuts provided specifically for probe purpose.

Static Structural Cyclic Sym. Model: External Load Path

Y-Direction (Toroidal) Deformation: Scale: 1.9E02



Static Structural Cyclic Sym. Model: External Load Path

Y-Direction (Toroidal) Deformation: Scale: 1.9E02



Static Structural Cyclic Sym. Model: Delamination

Y-Direction (Toroidal) Deformation: Scale: 1.9E02

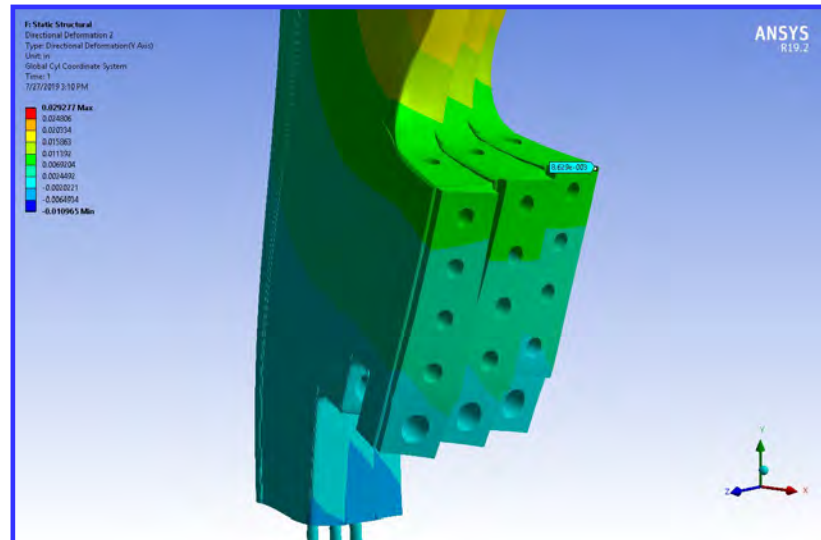
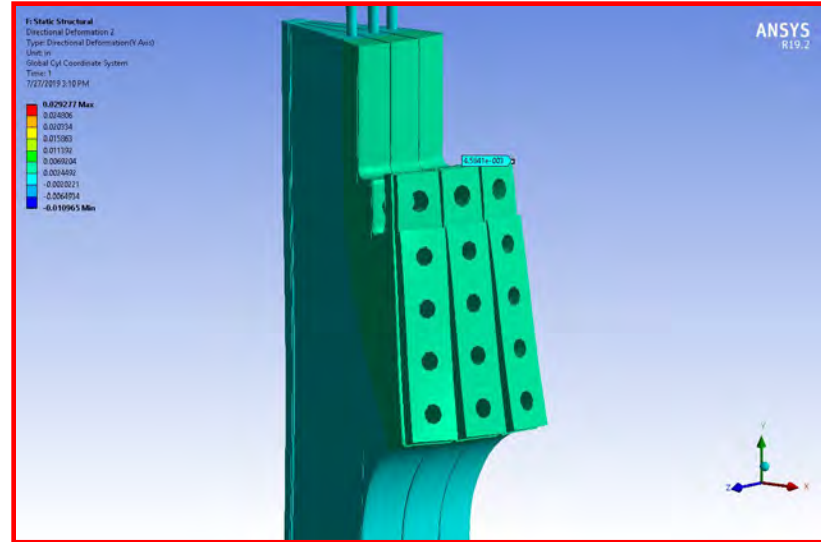
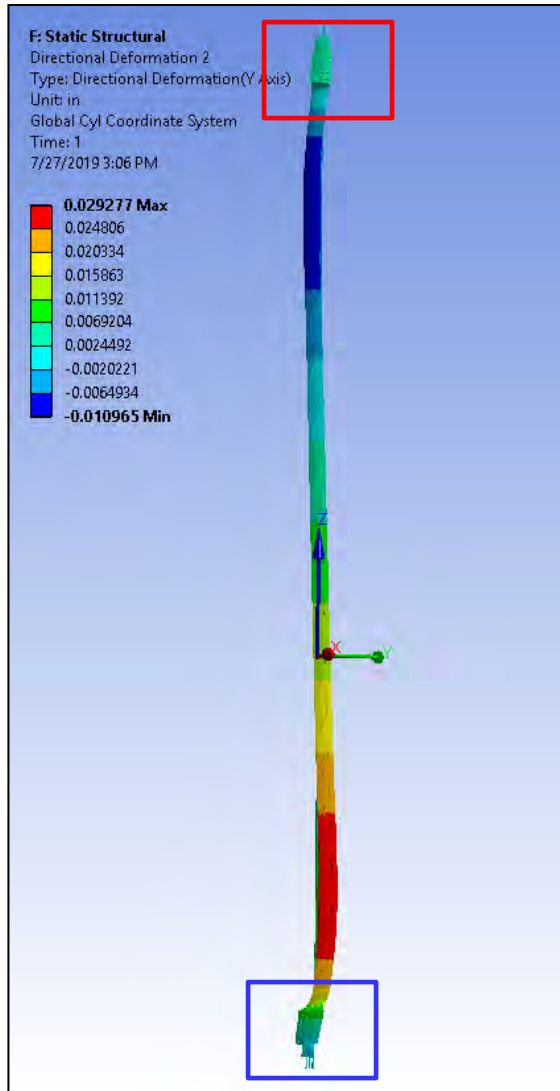

Static Structural Cyclic Sym. Model: Delamination

Y-Direction (Toroidal) Deformation: Scale: 1.9E02

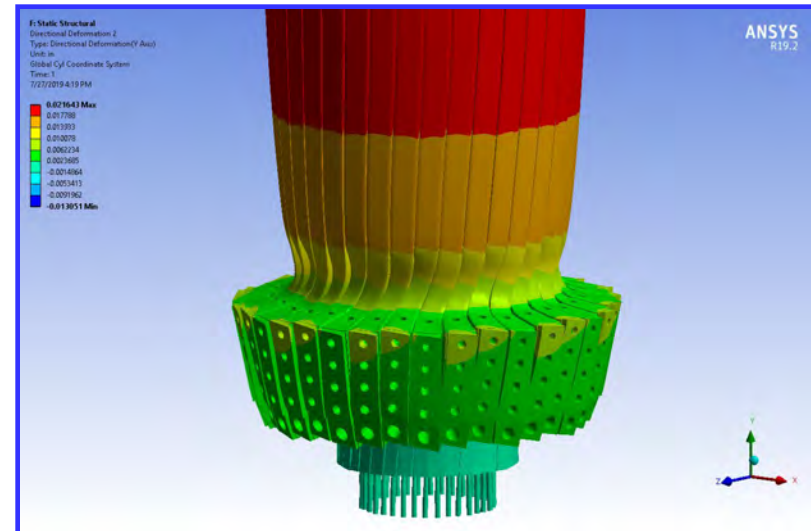
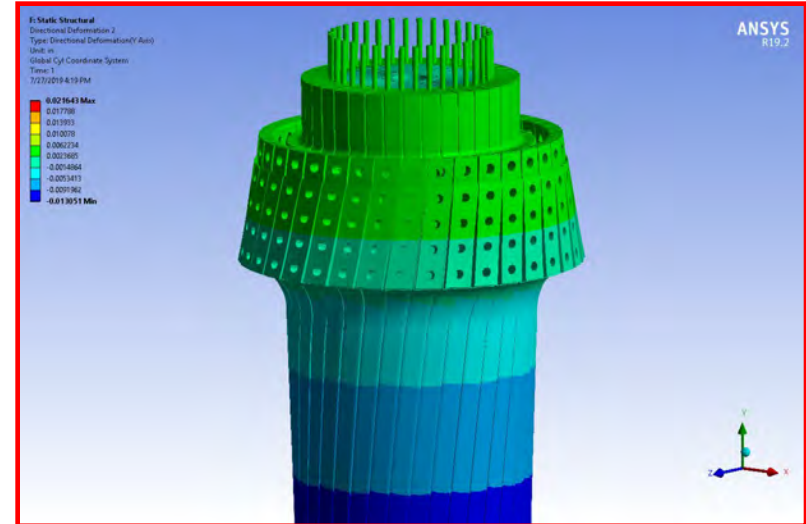
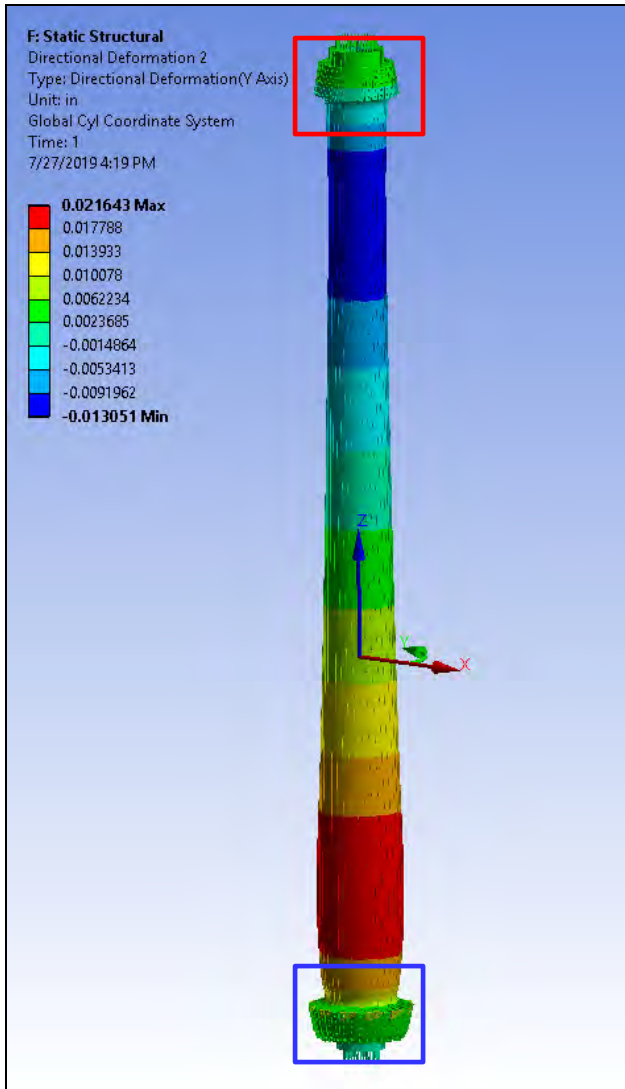

Appendix

Static Structural Umbrella Lid Model: Reaction Force 8 mm (.31") Center Deflection/ TF Bundle Thermal Growth

ANSYS
R19.2

H: Static Structural
Force Reaction
3/29/2019 3:48 PM

$R / \#Flags = 7327.6 \text{ lbf}/36$
 $= 203.5 \text{ lbf}/ \text{Flag}$

$K = 7327.6 \text{ lbf}/.31 \text{ in}$
 $= 23,637 \text{ lbf}/ \text{in}$

Details of "Force Reaction"	
Definition	
Type	Force Reaction
Location Method	Boundary Condition
Boundary Condition	Fixed Support
Orientation	Global Coordinate System
Suppressed	No
Options	
Result Selection	All
<input type="checkbox"/> Display Time	End Time
Results	
Maximum Value Over Time	
<input type="checkbox"/> X Axis	-1.5732e-003 lbf
<input type="checkbox"/> Y Axis	2.5869e-004 lbf
<input type="checkbox"/> Z Axis	7327.6 lbf
<input type="checkbox"/> Total	7327.6 lbf
Minimum Value Over Time	
<input type="checkbox"/> X Axis	-1.5732e-003 lbf
<input type="checkbox"/> Y Axis	2.5869e-004 lbf
<input type="checkbox"/> Z Axis	7327.6 lbf
<input type="checkbox"/> Total	7327.6 lbf
Information	

0.00 10.00 20.00 30.00 40.00 (in)



Static Structural Umbrella Lid Model: Torsional Spring Rate

I.D. = 20 in, Test Torque = 100K lbf-in

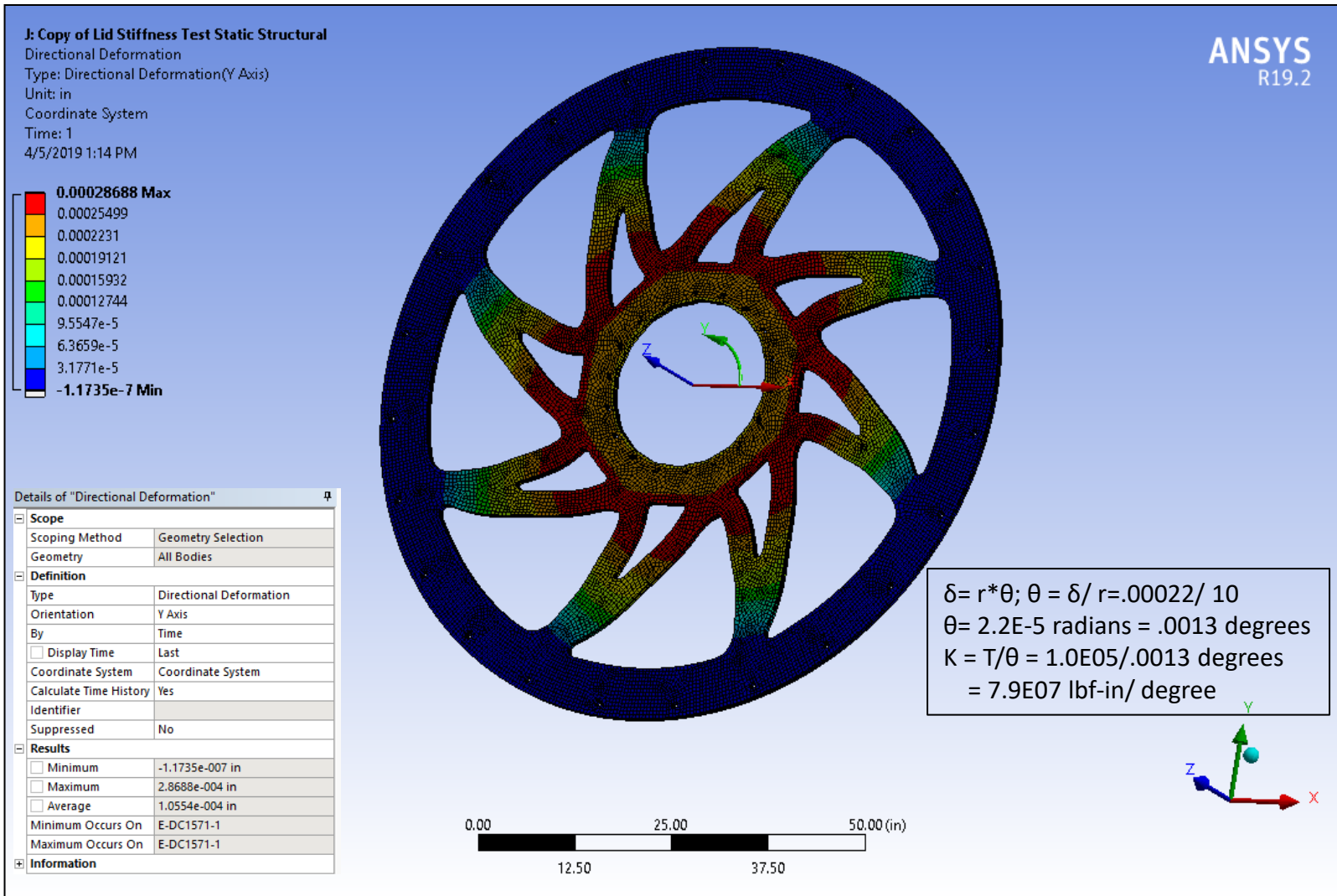

Static Structural Pedestal Model: Vertical Spring Rate

Test Force = 5E04 lbf

ANSYS
R19.2

P: Baseline Pedestal Stiffness

Directional Deformation
Type: Directional Deformation(Y Axis)
Unit: in
Global Coordinate System
Time: 1
6/19/2019 11:20 AM

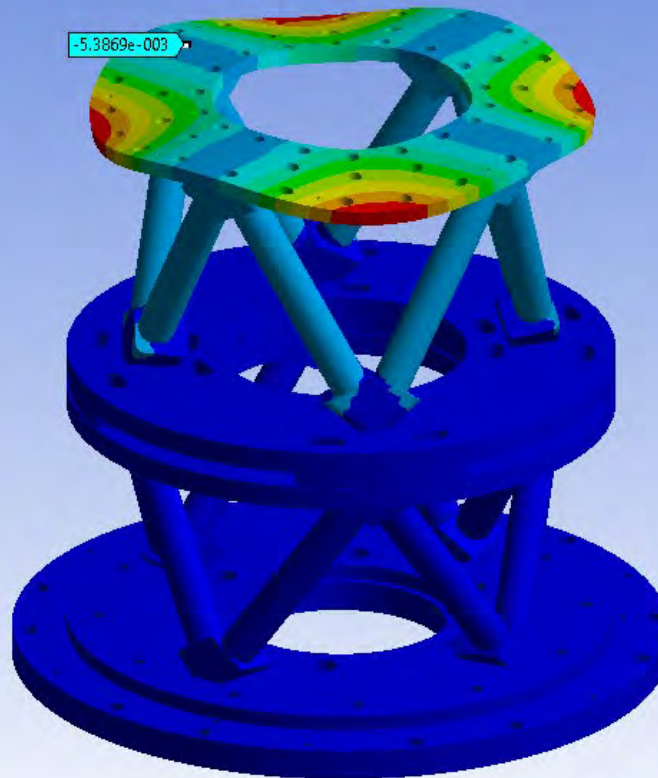
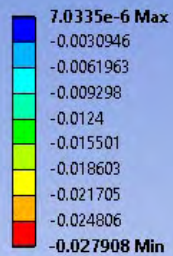

$$K = 5E04 \text{ lbf}/.0059 \text{ in} \\ = 8.47E06 \text{ lbf}/\text{in}$$

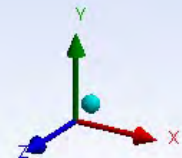

Details of "Directional Deformation"

Scope	
Scoping Method	Geometry Selection
Geometry	All Bodies
Definition	
Type	Directional Deformation
Orientation	Y Axis
By	Time
<input type="checkbox"/> Display Time	1. s
Coordinate System	Global Coordinate System
Calculate Time History	Yes
Identifier	
Suppressed	No
Results	
<input type="checkbox"/> Minimum	-2.7908e-002 in
<input type="checkbox"/> Maximum	7.0335e-006 in
<input type="checkbox"/> Average	-2.0916e-003 in
Minimum Occurs On	E-DC1564-2\Imported1
Maximum Occurs On	E-DC1694-1\Imported1
Minimum Value Over Time	
<input type="checkbox"/> Minimum	-2.7908e-002 in
<input type="checkbox"/> Maximum	-2.7597e-004 in
Maximum Value Over Time	
<input type="checkbox"/> Minimum	7.0335e-006 in
<input type="checkbox"/> Maximum	2.7469e-004 in
Information	

Static Structural Pedestal Model: Torsional Spring Rate

O.D. = 33 in, Test Torque = 100K lbf-in

ANSYS
R19.2

M: Static Structural
 Directional Deformation 2
 Type: Directional Deformation(Y Axis)
 Unit: in
 Coordinate System
 Time: 2
 5/17/2019 11:35 AM

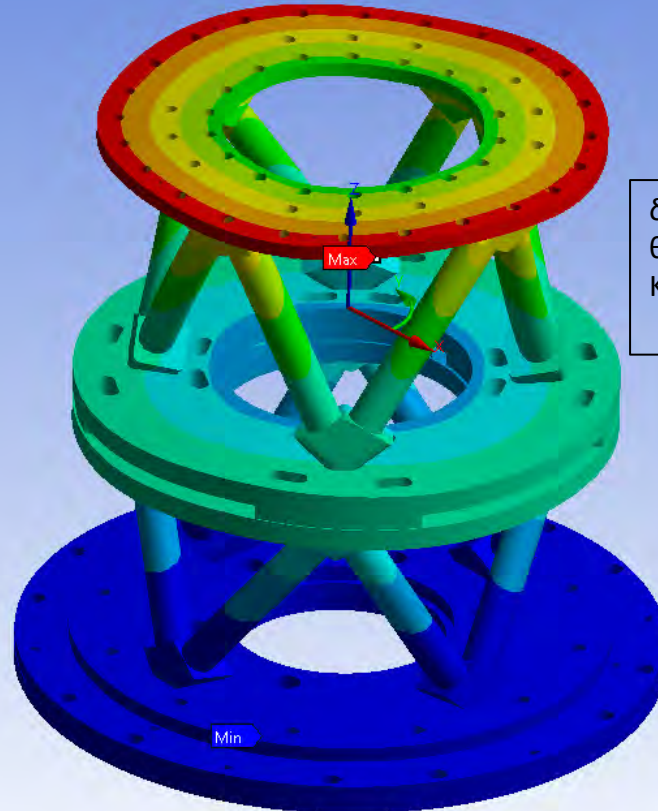

$$\delta = r * \theta; \theta = \delta / r = .00303'' / 16.5''$$

$$\theta = 1.8E-4 \text{ radians} = .0105 \text{ degrees}$$

$$K = T / \theta = 1.0E05 / .0105 \text{ degrees}$$

$$= 9.5E06 \text{ lbf-in/ degree}$$

Details of "Directional Deformation 2"

Scope	
Scoping Method	Geometry Selection
Geometry	All Bodies
Definition	
Type	Directional Deformation
Orientation	Y Axis
By	Time
<input type="checkbox"/> Display Time	Last
Coordinate System	Coordinate System
Calculate Time History	Yes
Identifier	
Suppressed	No
Results	
<input type="checkbox"/> Minimum	0. in
<input type="checkbox"/> Maximum	3.0281e-003 in
<input type="checkbox"/> Average	5.6258e-004 in
Minimum Occurs On	E-DC1694-1\Imported1
Maximum Occurs On	E-DC1564-2\Imported1
Minimum Value Over Time	
<input type="checkbox"/> Minimum	-1.3801e-003 in
<input type="checkbox"/> Maximum	0. in
Maximum Value Over Time	
<input type="checkbox"/> Minimum	1.3836e-003 in
<input type="checkbox"/> Maximum	3.0281e-003 in
Information	

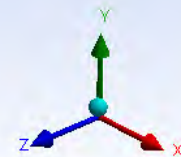
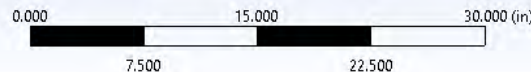

Static Structural Cyclic Pedestal Model: Vertical Spring Rate

Test Force = 5E04 lbf

ANSYS
R19.2

Q: Copy of Baseline Pedestal Stiffness

Directional Deformation
Type: Directional Deformation(Y Axis)
Unit: in
Global Coordinate System
Time: 1
6/19/2019 11:13 AM

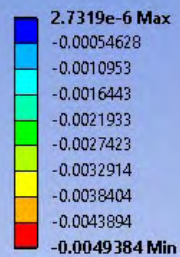

$K = 5E04 \text{ lbf}/.0049 \text{ in}$
 $= 1.02E07 \text{ lbf}/\text{in}$

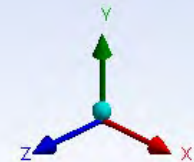
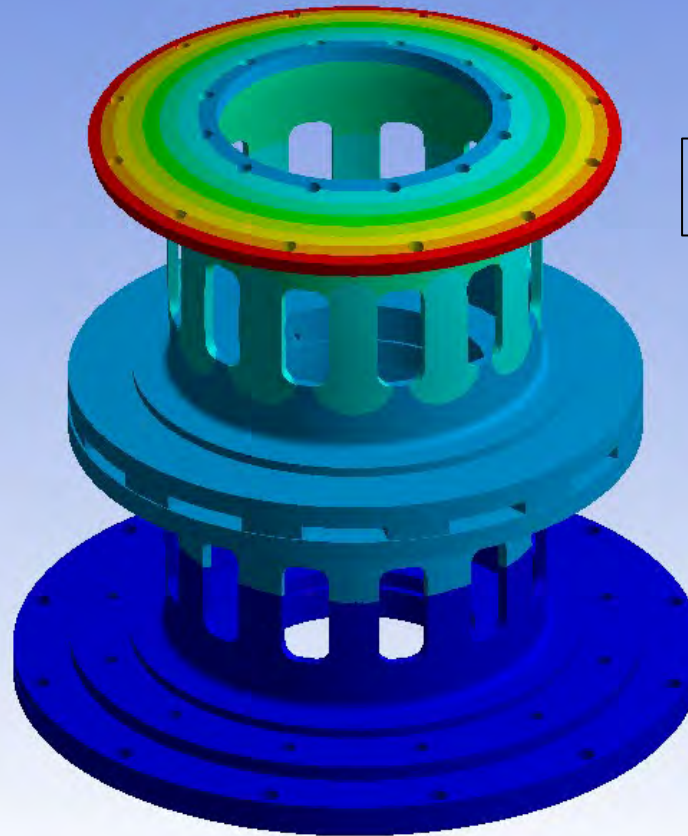

Details of "Directional Deformation"	
Scope	
Scoping Method	Geometry Selection
Geometry	All Bodies
Definition	
Type	Directional Deformation
Orientation	Y Axis
By	Time
<input type="checkbox"/> Display Time	1. s
Coordinate System	Global Coordinate System
Calculate Time History	Yes
Identifier	
Suppressed	No
Results	
<input type="checkbox"/> Minimum	-4.9384e-003 in
<input type="checkbox"/> Maximum	2.7319e-006 in
<input type="checkbox"/> Average	-6.7156e-004 in
Minimum Occurs On	E-DC1564-2_Cyclic Sym
Maximum Occurs On	E-DC1694-1_Cyclic Sym
Minimum Value Over Time	
<input type="checkbox"/> Minimum	-4.9384e-003 in
<input type="checkbox"/> Maximum	-2.1068e-004 in
Maximum Value Over Time	
<input type="checkbox"/> Minimum	2.7319e-006 in
<input type="checkbox"/> Maximum	2.0841e-004 in
Information	

Static Structural Cyclic Pedestal Model: Torsional Spring Rate

O.D. = 33 in, Test Torque = 100K lbf-in

ANSYS
R19.2

Q: Copy of Baseline Pedestal Stiffness

Directional Deformation 2

Type: Directional Deformation(Y Axis)

Unit: in

Coordinate System

Time: 2

6/19/2019 11:01 AM

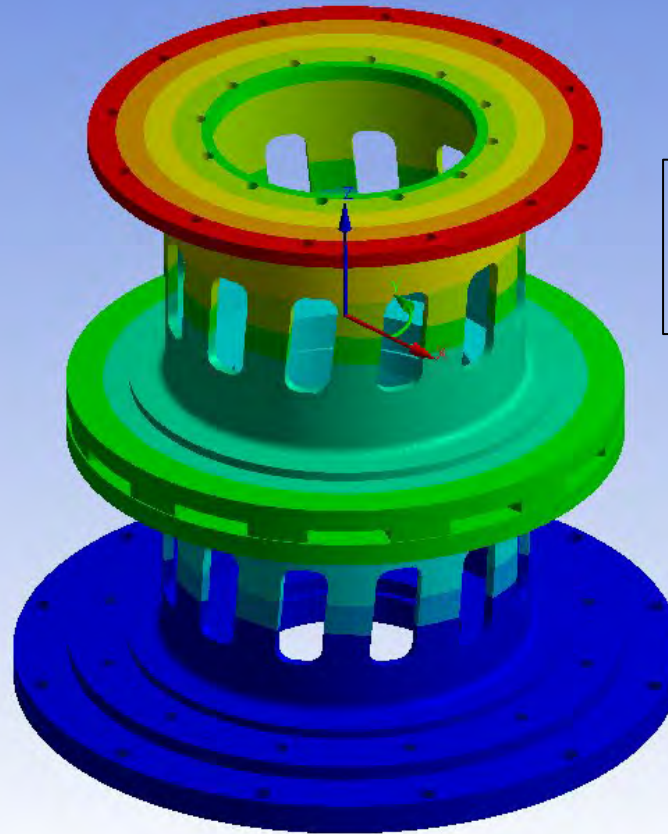
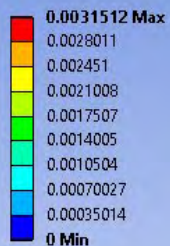

$$\delta = r \cdot \theta; \theta = \delta / r = .00315'' / 16.5''$$

$$\theta = 1.9E-4 \text{ radians} = .0109 \text{ degrees}$$

$$K = T / \theta = 1.0E05 / .0109 \text{ degrees}$$

$$= 9.2E06 \text{ lbf-in/degree}$$

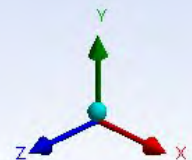

Details of "Directional Deformation 2"

Scope	
Scoping Method	Geometry Selection
Geometry	All Bodies
Definition	
Type	Directional Deformation
Orientation	Y Axis
By	Time
<input type="checkbox"/> Display Time	Last
Coordinate System	Coordinate System
Calculate Time History	Yes
Identifier	
Suppressed	No
Results	
<input type="checkbox"/> Minimum	0. in
<input type="checkbox"/> Maximum	3.1512e-003 in
<input type="checkbox"/> Average	7.5506e-004 in
Minimum Occurs On	E-DC1694-1-1_Cyclic Sym
Maximum Occurs On	E-DC1564-2_Cyclic Sym
Minimum Value Over Time	
<input type="checkbox"/> Minimum	-3.2663e-005 in
<input type="checkbox"/> Maximum	0. in
Maximum Value Over Time	
<input type="checkbox"/> Minimum	4.7687e-005 in
<input type="checkbox"/> Maximum	3.1512e-003 in
Information	

Static Structural Skirt Model: Vertical Spring Rate

Test Force = 1E04 lbf

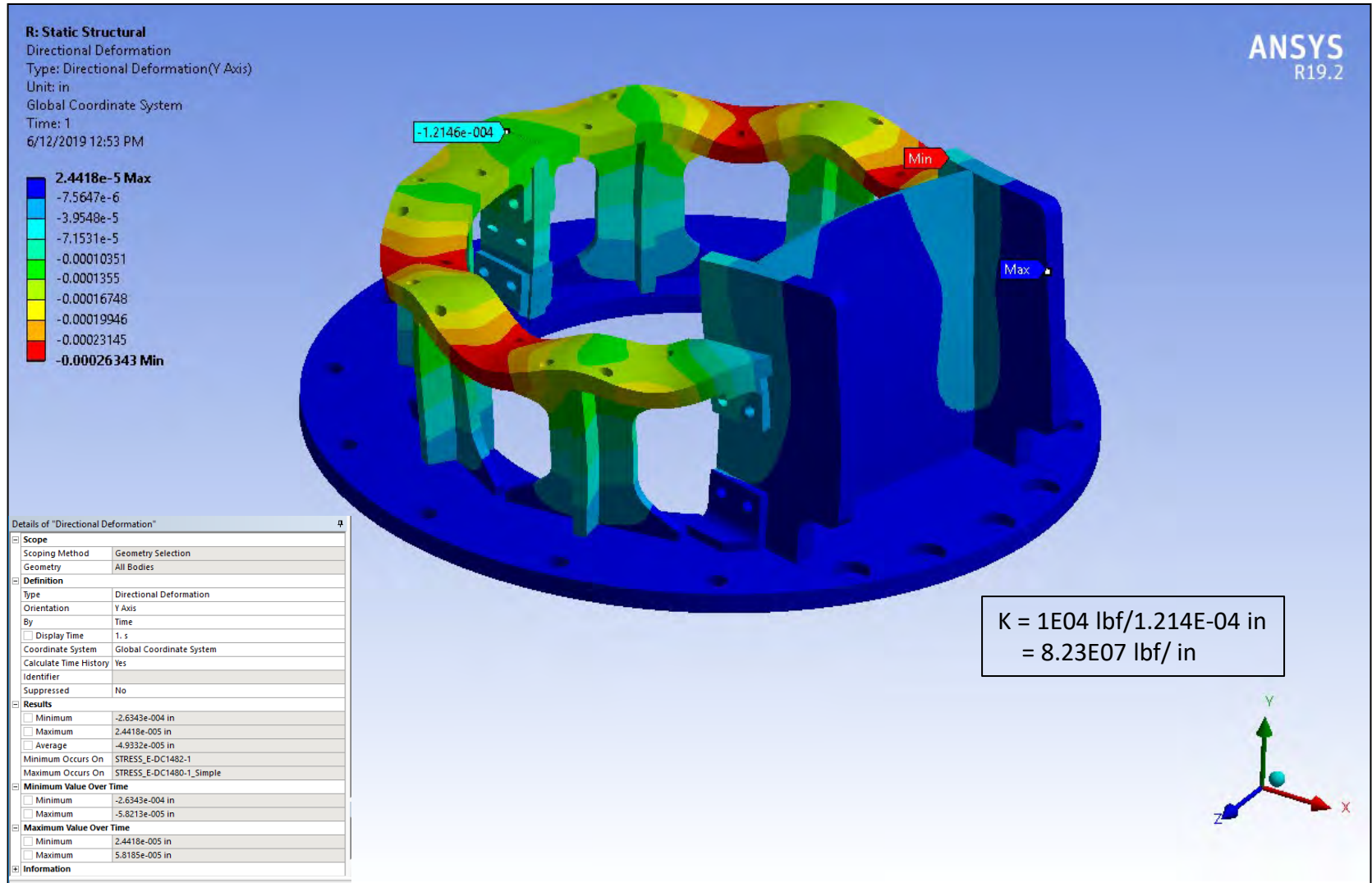

Static Structural Skirt Model: Torsional Spring Rate

O.D. = 21.89 in, Test Torque = 10K lbf-in

ANSYS
R19.2

R: Static Structural

Directional Deformation 2
Type: Directional Deformation(Y Axis)
Unit: in
Coordinate System
Time: 2
6/12/2019 1:20 PM

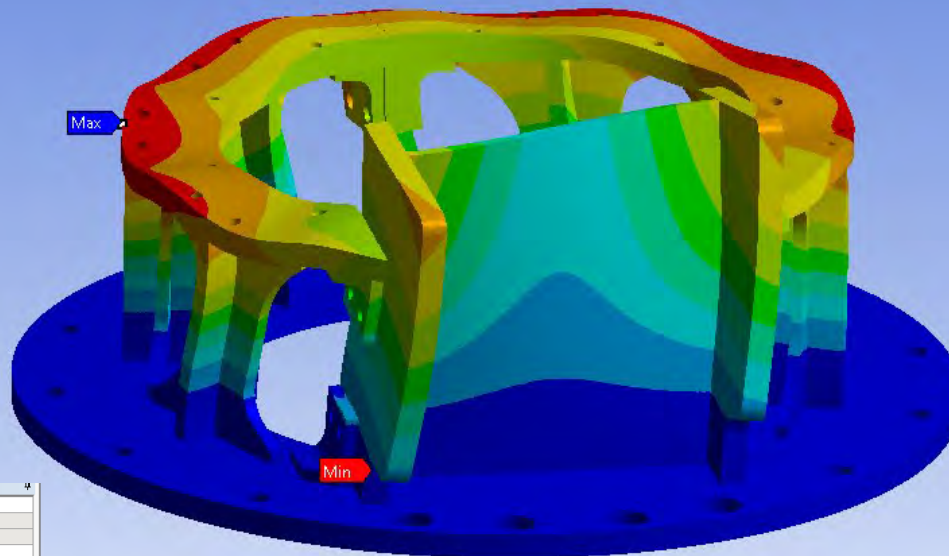

Details of "Directional Deformation 2"	
Scope	
Scoping Method	Geometry Selection
Geometry	All Bodies
Definition	
Type	Directional Deformation
Orientation	Y Axis
By	Time
<input type="checkbox"/> Display Time	Last
Coordinate System	Coordinate System
Calculate Time History	Yes
Identifier	
Suppressed	No
Results	
<input type="checkbox"/> Minimum	-4.4901e-007 in
<input type="checkbox"/> Maximum	1.5358e-004 in
<input type="checkbox"/> Average	4.2105e-005 in
Minimum Occurs On	STRESS_E-DC1480-3
Maximum Occurs On	STRESS_E-DC1482-1_2
Minimum Value Over Time	
<input type="checkbox"/> Minimum	-1.2093e-004 in
<input type="checkbox"/> Maximum	-4.4901e-007 in
Maximum Value Over Time	
<input type="checkbox"/> Minimum	1.2114e-004 in
<input type="checkbox"/> Maximum	1.5358e-004 in
Information	

$$\delta = r * \theta; \theta = \delta / r = .00015" / 10.95"$$

$$\theta = 1.4E-5 \text{ radians} = 8.0E-4 \text{ degrees}$$

$$K = T / \theta = 1.0E04 / 8.0E-4 \text{ degrees}$$

$$= 1.25E07 \text{ lbf-in/ degree}$$

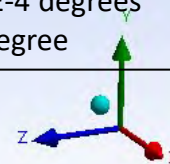

Static Structural Cyclic Skirt Model: Vertical Spring Rate

Test Force = 1E04 lbf

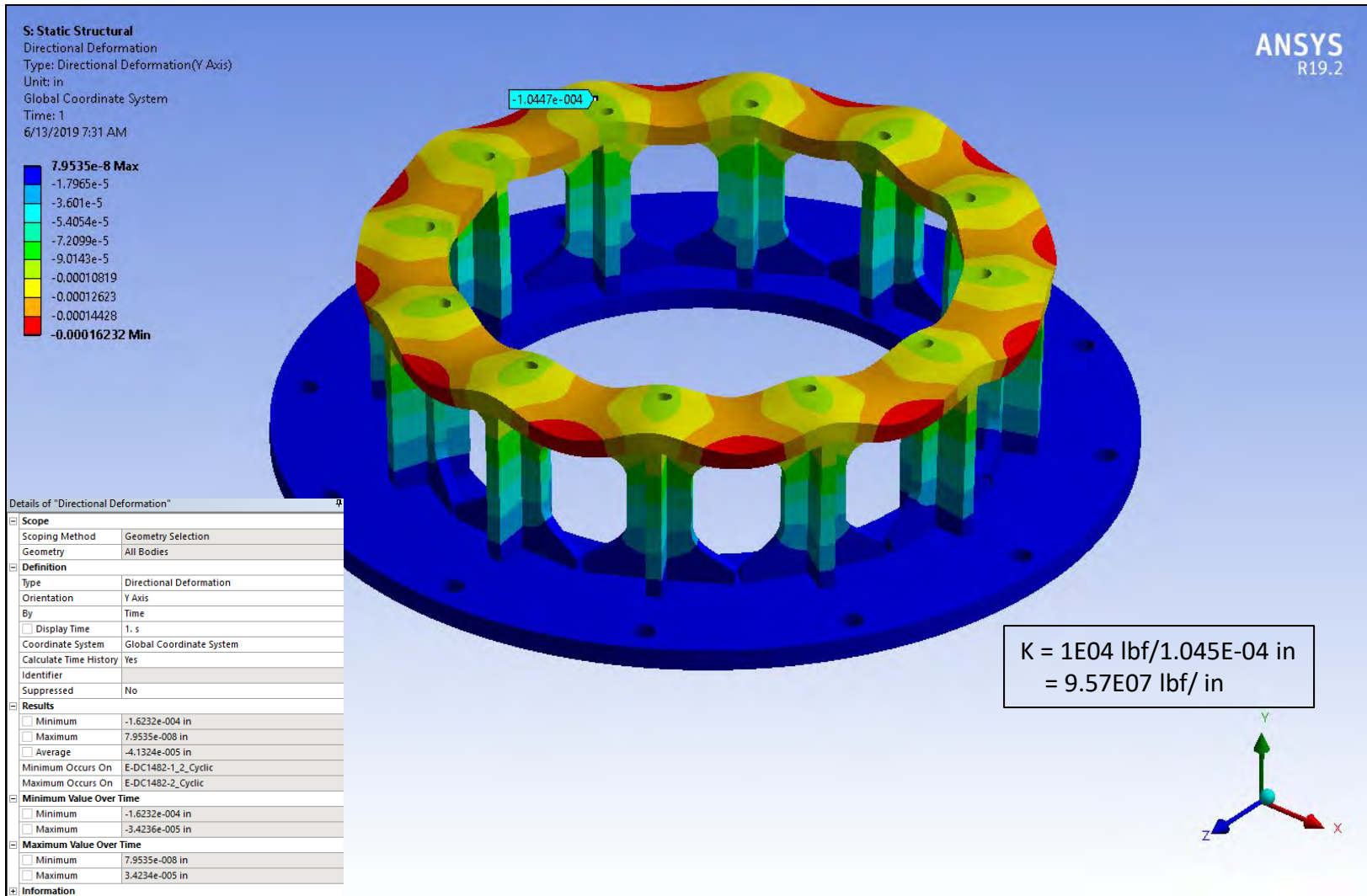

Static Structural Cyclic Skirt Model: Torsional Spring Rate

O.D. = 21.89 in, Test Torque = 10K lbf-in

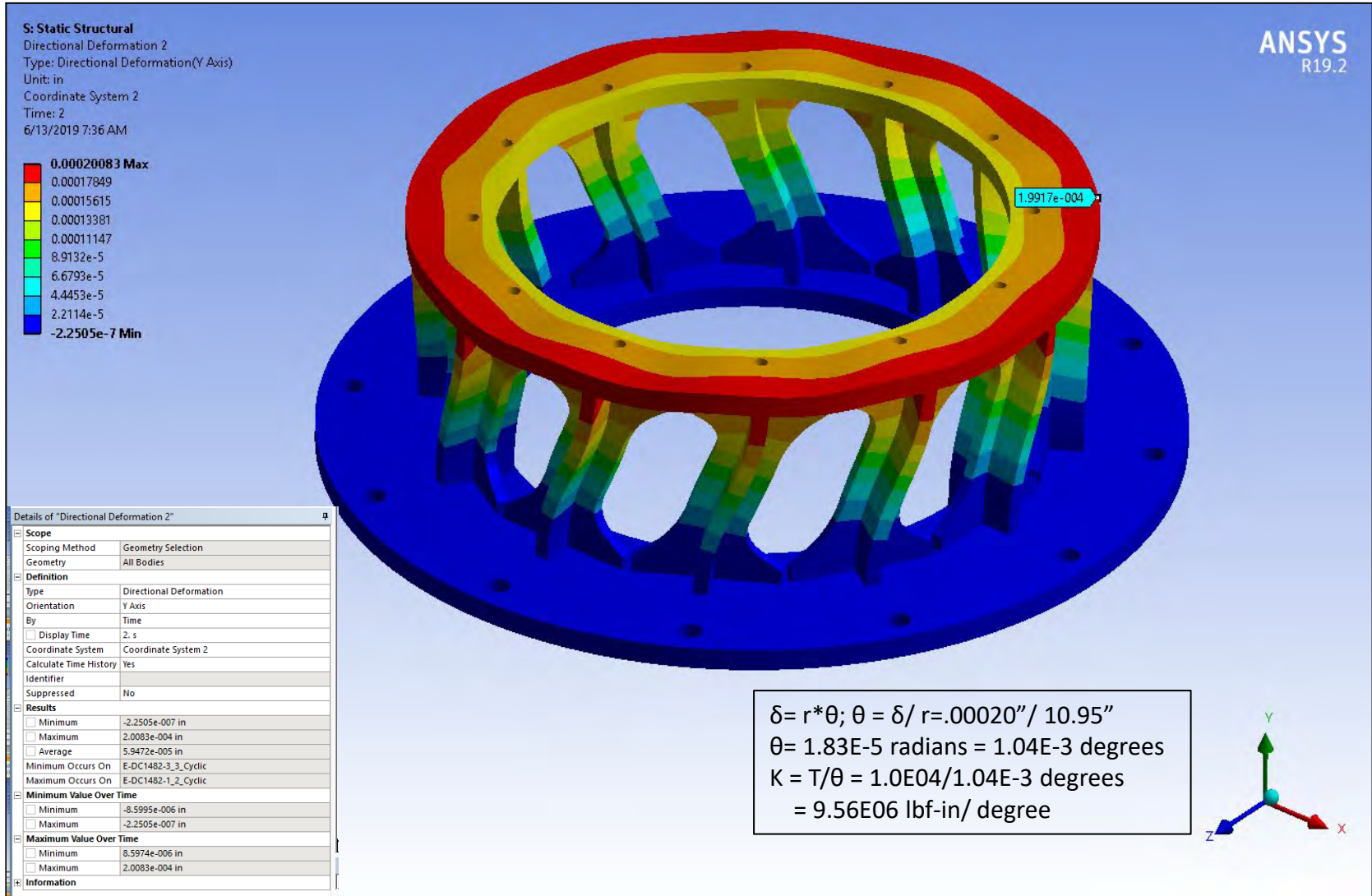

Static Structural Vessel Supports Model: Vertical Spring Rate

Test Force = 1E05 lbf

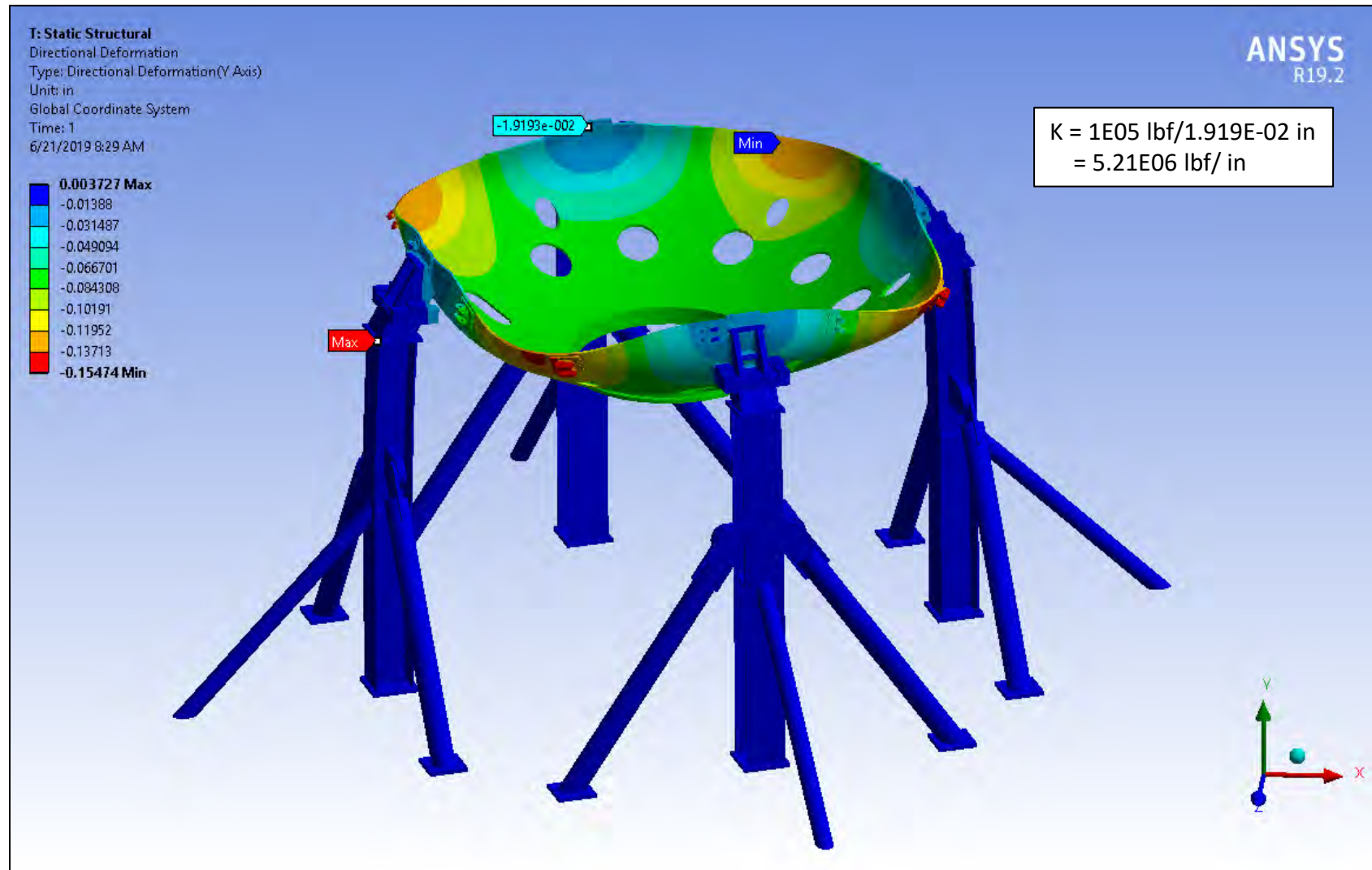

Static Structural Vessel Support Legs Model: Torsional Spring Rate

O.D. = 134.25 in, Test Torque = 100k lbf-in

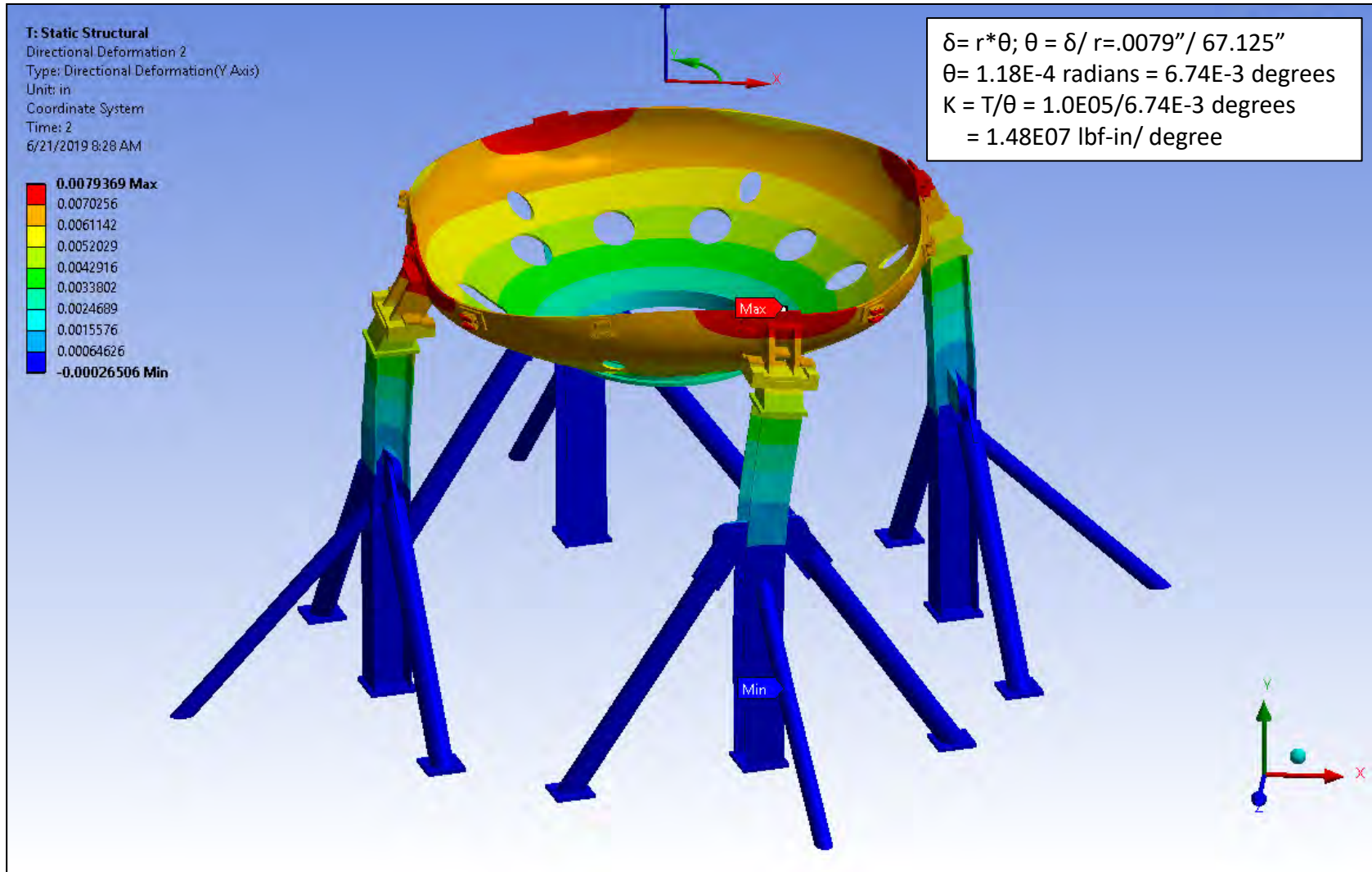

Static Structural Cyclic Vessel Support Legs Model: Vertical Spring Rate

Test Force = 1E05 lbf

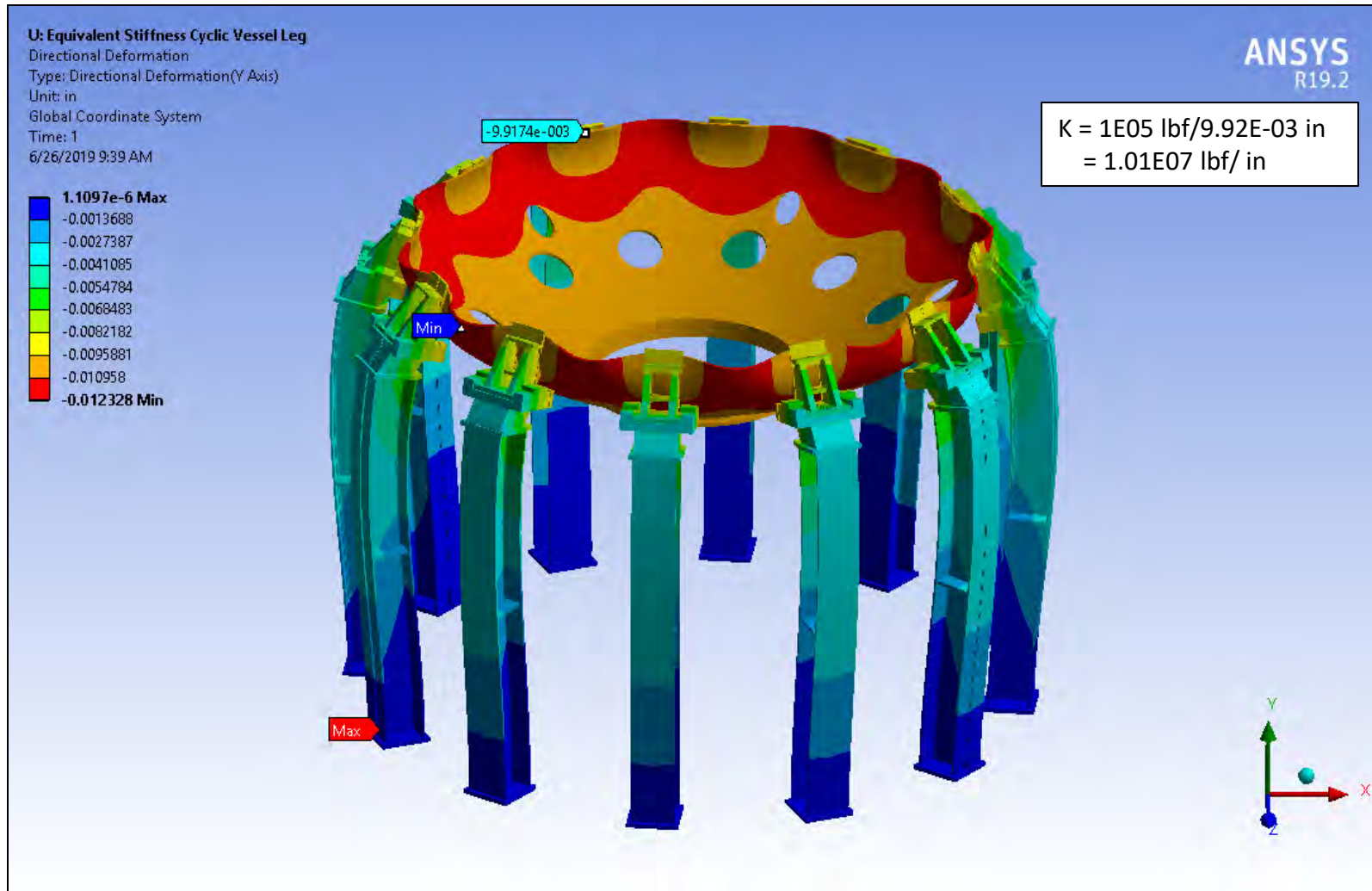

Static Structural Cyclic Vessel Support Legs: Torsional Spring Rate

O.D. = 134.25 in, Test Torque = 100K lbf-in

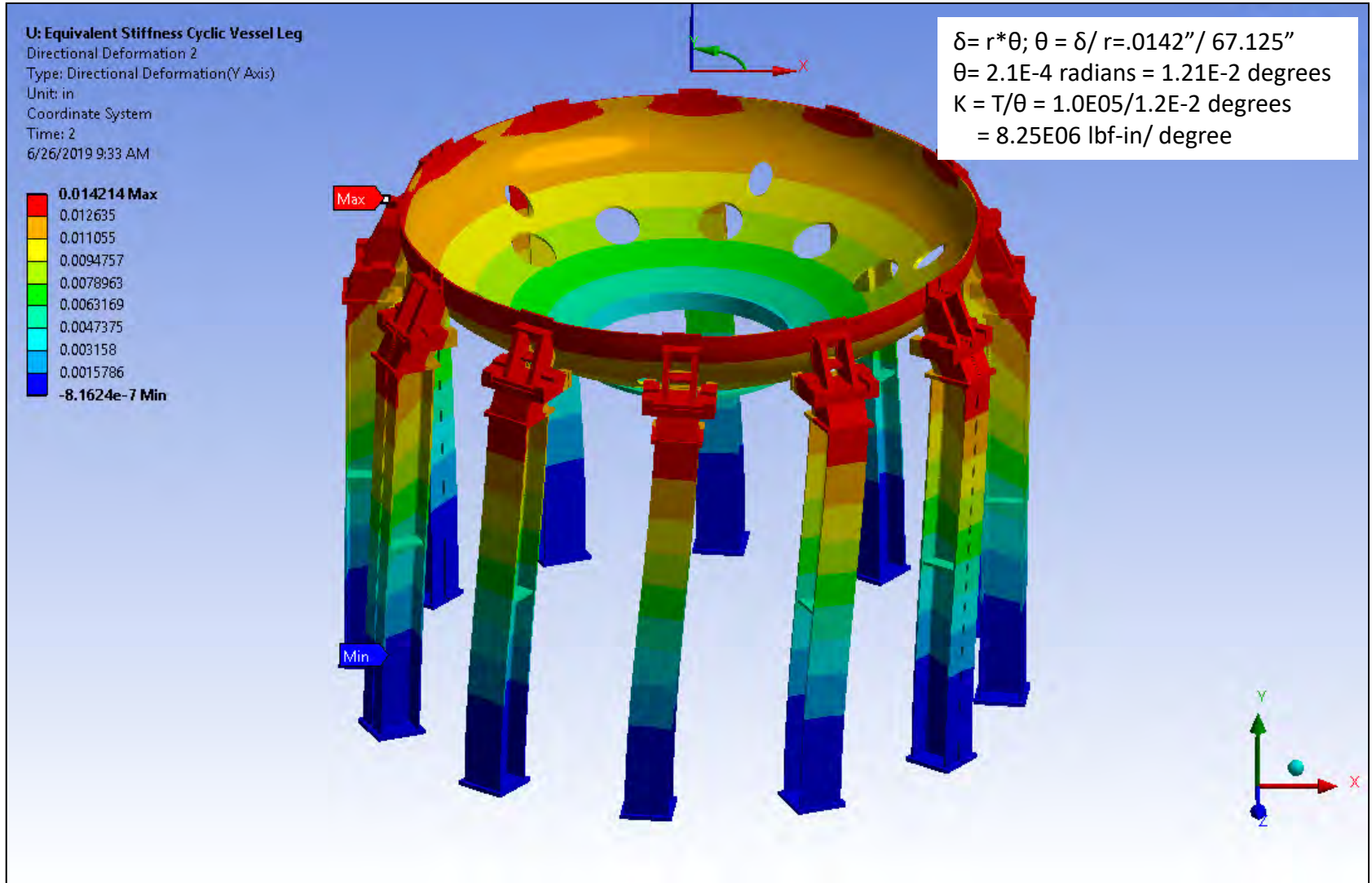

Upper Umbrella Region

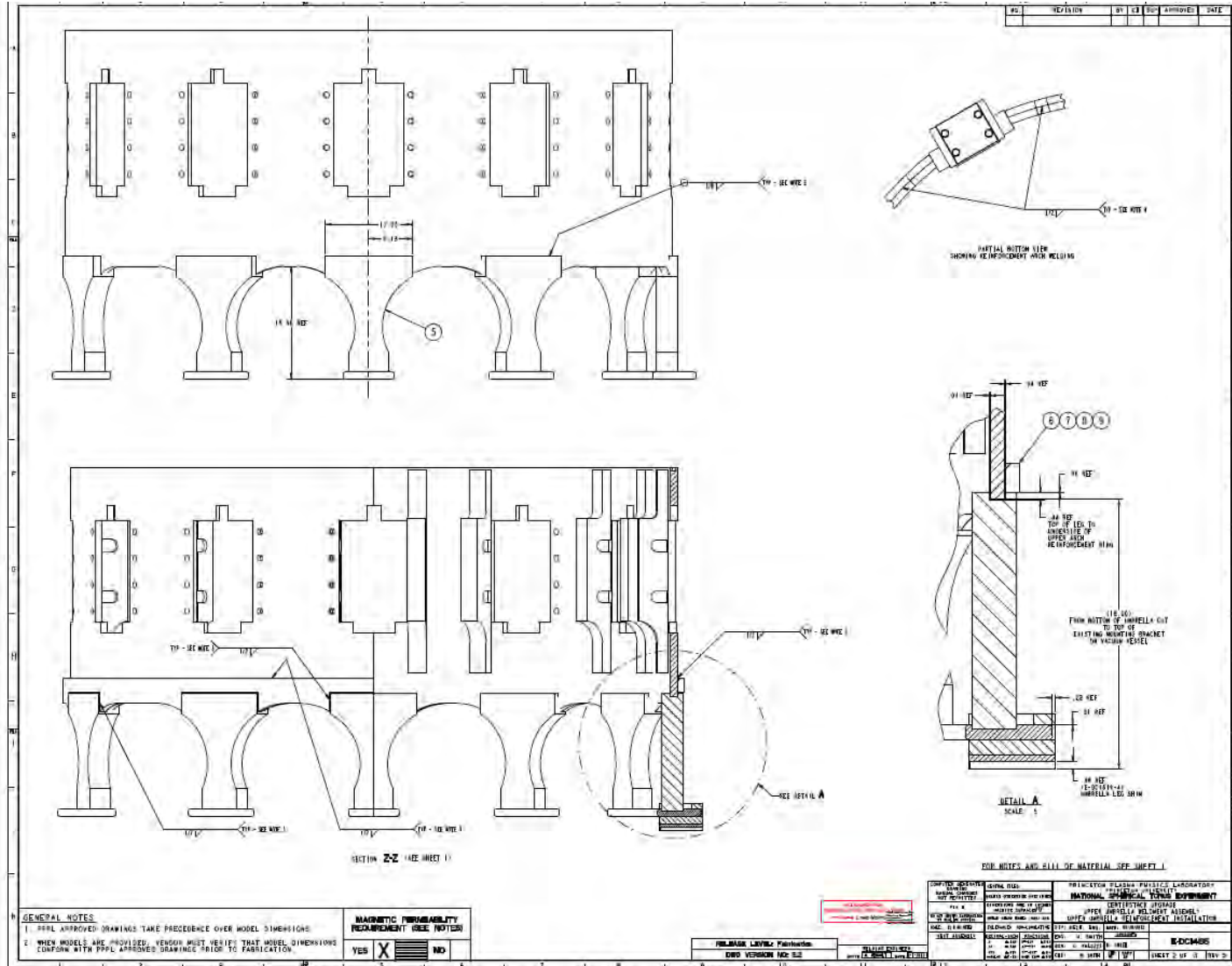

Upper Umbrella Region

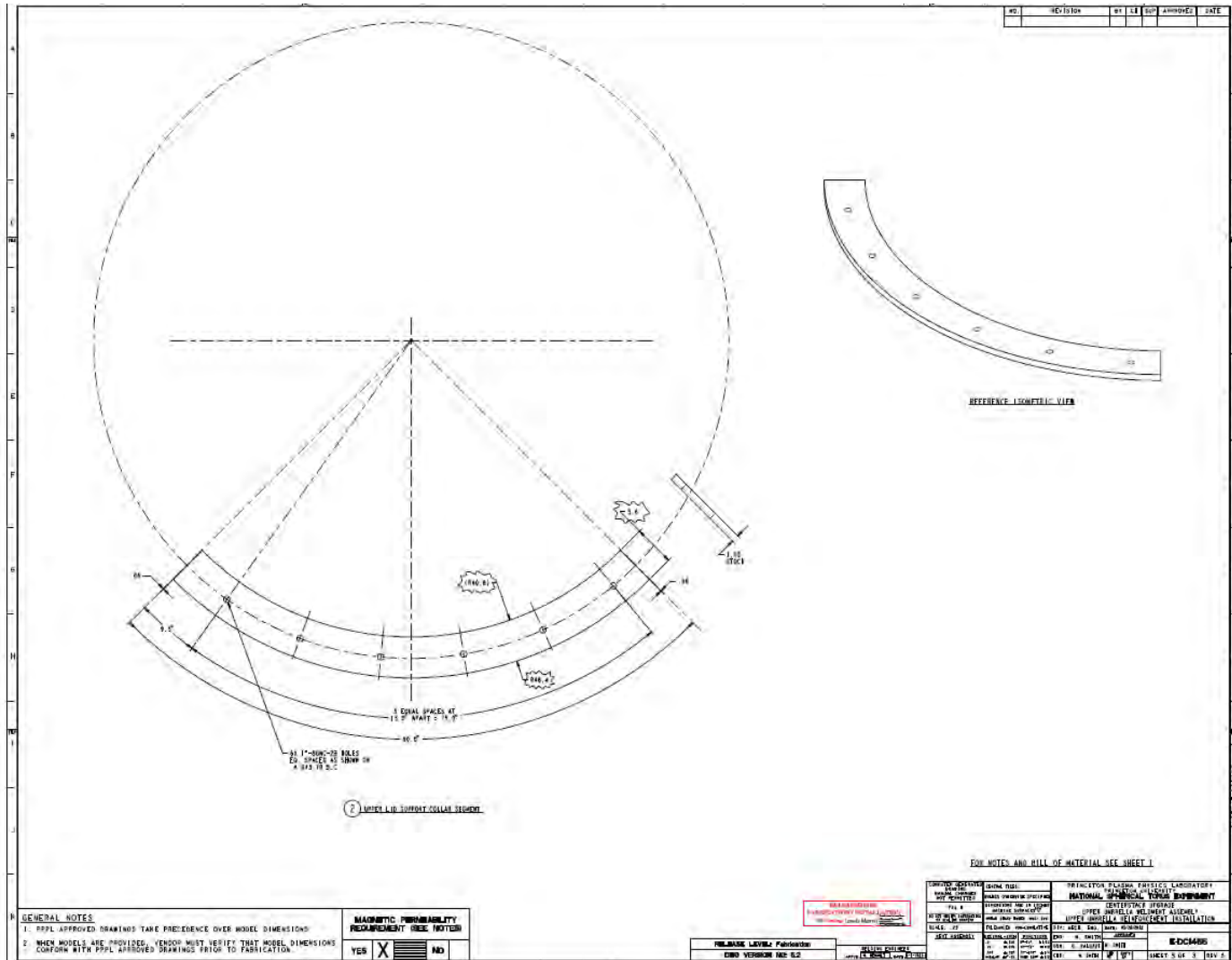

Upper Umbrella Region

